

5 June 1998

AGREEMENT

**CONCERNING THE ADOPTION OF UNIFORM TECHNICAL PRESCRIPTIONS
FOR WHEELED VEHICLES, EQUIPMENT AND PARTS WHICH CAN BE FITTED
AND/OR
BE USED ON WHEELED VEHICLES AND THE CONDITIONS FOR RECIPROCAL
RECOGNITION
OF APPROVALS GRANTED ON THE BASIS OF THESE PRESCRIPTIONS */**

(Revision 2, including the amendments entered into force on 16 October 1995)

Addendum 43: Regulation No. 44

Revision 1

Incorporating:

01 series of amendments - Date of entry into force: 17 November 1982

Corrigendum 1 to the 01 series of amendments subject of Depository Notification C.N.398.1983.TREATIES-6 dated 26 January 1984

02 series of amendments - Date of entry into force: 4 April 1986

Supplement 1 to the 02 series of amendments - Date of entry into force: 8 November 1987

Supplement 2 to the 02 series of amendments - Date of entry into force: 28 February 1989

Supplement 3 to the 02 series of amendments - Date of entry into force: 29 November 1990

Corrigendum 1 to the original version of the Regulation subject of Depository Notification C.N.232.1992.TRE, dated 11 September 1992

Corrigendum 1 to the 02 series of amendments subject of Depository Notification C.N.232.1992.TREATIES-3 dated 11 September 1992

Supplement 4 to the 02 series of amendments - Date of entry into force: 26 January 1994

03 series of amendments - Date of entry into force: 12 September 1995

Corrigendum 1 to the 03 series of amendments subject of Depository Notification C.N.204.1995.TREATIES-3 dated 7 August 1995

Corrigendum 2 to the 03 series of amendments subject of Depository Notification C.N.227.1997.TREATIES-4 dated 20 June 1997

Supplement 1 to the 03 series of amendments - Date of entry into force: 18 January 1998

Corrigendum 3 to the 03 series of amendments subject of Depository Notification C.N.44.1998.TREATIES-2E dated 9 March 1998

**UNIFORM PROVISIONS CONCERNING THE APPROVAL OF
RESTRAINING DEVICES FOR CHILD OCCUPANTS OF POWER-DRIVEN VEHICLES
('CHILD RESTRAINT SYSTEM')**



UNITED NATIONS

*/ Former title of the Agreement:

Agreement Concerning the Adoption of Uniform Conditions of Approval and Reciprocal Recognition of Approval at Geneva on 20 March 1958.

Regulation No. 44

UNIFORM PROVISIONS CONCERNING THE APPROVAL OF RESTRAINING DEVICES
FOR CHILD OCCUPANTS OF POWER-DRIVEN VEHICLES
("CHILD RESTRAINT SYSTEM")

CONTENTS

REGULATION	<u>Page</u>
1. Scope	6
2. Definitions	6
3. Application for approval	12
4. Markings	13
5. Approval	14
6. General specifications	15
7. Particular specifications	20
8. Description of tests	33
9. Test report	51
10. Modifications and extension of approval of a type of child restraint system	51
11. Conformity of production	52
12. Penalties for non-conformity of production	53
13. Production definitely discontinued	53
14. Instructions	54
15. Names and addresses of technical services responsible for conducting approval tests, and of administrative departments	56
16. Transitional provisions	57

CONTENTS (continued)

ANNEXES

- Annex 1 - Communication concerning the approval or extension or refusal or withdrawal of approval or production definitely discontinued of restraining devices for child occupants of power-driven vehicles, pursuant to Regulation No. 44
- Annex 2 - Arrangements of the approval mark
- Annex 3 - Arrangement of apparatus for dust resistance test
- Annex 4 - Corrosion test
- Annex 5 - Abrasion and microslip test
- Annex 6 - Description of trolley
- Annex 7 - Curve of the trolley's deceleration as a function of time
- Annex 7 - Appendix 1 - Curves of the trolley's deceleration as a function of time (Curve for calibrating a stopping device) - Frontal impact
- Annex 7 - Appendix 2 - Curves of the trolley's deceleration as a function of time (Curve for calibrating a stopping device) - Rear impact
- Annex 8 - Description of manikins
- Annex 8 - Appendix 1 - Description of the 9 months and 3, 6 and 10-year manikins
- Annex 8 - Appendix 2 - Description of the "new-born" manikin
- Annex 8 - Appendix 3 - Description of the 18 months manikin
- Annex 9 - Frontal impact test against a barrier
- Annex 10 - Rear impact test procedure
- Annex 11 - Additional anchorages required for attaching child restraints in the semi-universal category to motor vehicles
- Annex 12 - Chair
- Annex 13 - Standard safety-belt
- Annex 14 - (not used - for the text of Annex 14 (former) see Annex 8 - Appendix 2
- Annex 15 - Explanatory notes
- Annex 16 - Control of conformity of production

CONTENTS (continued)

- Annex 17 - Test of energy absorbing material
- Annex 18 - Method of defining head impact area of devices with backrests and for rearward-facing devices defining the minimum size of side wings
- Annex 19 - Description of conditioning of adjusters mounted directly on child restraints
- Annex 20 - Typical buckle strength test device
- Annex 21 - Dynamic crash test installation
-

1. SCOPE

- 1.1. This Regulation applies to child restraint systems which are suitable for installation in power-driven vehicles having three or more wheels, and which are not intended for use with folding (tip-up) or with side-facing seats.

2. DEFINITIONS

For the purpose of this Regulation:

- 2.1. Child restraint system ('restraint') means an arrangement of components which may comprise the combination of straps or flexible components with a securing buckle, adjusting devices, attachments and in some cases a supplementary device as a carry-cot, infant carrier, a supplementary chair and/or an impact shield, capable of being anchored to a power-driven vehicle. It is so designed as to diminish the risk of injury to the wearer, in the event of a collision or of abrupt deceleration of the vehicle, by limiting the mobility of the wearer's body.

- 2.1.1. Child restraints fall into five "mass groups":

2.1.1.1. group 0 for children of a mass less than 10 kg;

2.1.1.2. group 0+ for children of a mass less than 13 kg;

2.1.1.3. group I for children of mass from 9 kg to 18 kg;

2.1.1.4. group II for children of mass from 15 kg to 25 kg;

2.1.1.5. group III for children of mass from 22 kg to 36 kg.

- 2.1.2. Child restraints fall into four "categories":

2.1.2.1. a "universal" category for use as specified in paragraphs 6.1.1. and 6.1.3.1. on most vehicle seat positions, and in particular those which have been assessed according to annex 13 - appendix 2 of the Consolidated Resolution on the Construction of Vehicles (R.E.3) */ as being compatible with such a category of child restraint;

2.1.2.2. a "restricted" category for use as specified in paragraphs 6.1.1. and 6.1.3.1. in designated seat positions for particular vehicle types as indicated by either the child restraint manufacturer or the vehicle manufacturer:

*/ Document TRANS/WP.29/78/Rev.1

- 2.1.2.3. a "semi-universal" category for use as specified in paragraphs 6.1.1. and 6.1.3.2;
- 2.1.2.4. a "specific vehicle" category for use either;
- 2.1.2.4.1. on specific vehicle types, in accordance with paragraphs 6.1.2. and 6.1.3.3.; or
- 2.1.2.4.2. as a "built in" child restraint.
- 2.1.3. Child restraint systems may be of two classes:
- an integral class comprising a combination of straps or flexible components with a securing buckle, adjusting device, attachments, and in some cases a supplementary chair and/or impact shield, capable of being anchored by means of its own integral strap or straps;
- a non-integral class that may comprise a partial restraint, which, when used in conjunction with an adult belt, which passes around the body of the child or restrains the device in which the child is placed, forms a complete child restraint system;
- 2.1.3.1. 'partial restraint' means a device, such as a booster cushion, which, when used in conjunction with an adult seat belt, which passes around the body of the child or restrains the device in which the child is placed, forms a complete child restraint system;
- 2.1.3.2. 'booster cushion' means a firm cushion, which can be used with an adult seat belt;
- 2.1.3.3. 'guide strap' means a strap which constrains the shoulder strap of the adult seat belt in a position to suit the child and where the effective position at which the shoulder strap changes direction can be adjusted by means of a device which can be moved up and down the strap to locate the wearer's shoulder, and then locked into that position. This guide strap is not meant to carry a significant part of the dynamic load.
- 2.2. 'Child-safety chair' means a child restraint incorporating a chair in which the child is held.
- 2.3. 'Belt' means a child restraint comprising a combination of straps with a securing buckle, adjusting devices and attachments;
- 2.4. 'Chair' means a structure which is a constituent part of the child restraint and is intended to accommodate a child in a seated position;

- 2.4.1. 'carry cot' means a restraint system intended to accommodate and restrain the child in a supine or prone position with the child's spine perpendicular to the median longitudinal plane of the vehicle. It is so designed as to distribute the restraining forces over the child's head and body excluding its limbs in the event of a collision;
- 2.4.2. 'carry-cot restraint' means a device used to restrain a carry-cot to the structure of the vehicle;
- 2.4.3. 'infant carrier' means a restraint system intended to accommodate the child in a rearward-facing semi-recumbent position. It is so designed as to distribute the restraining forces over the child's head and body excluding its limbs in the event of the frontal collision.
- 2.5. 'Chair support' means that part of a child restraint by which the chair can be raised.
- 2.6. 'Child support' means that part of a child restraint by which the child can be raised within the child restraint.
- 2.7. 'Impact shield' means a device secured in front of the child and designed to distribute the restraining forces over the greater part of the height of the child's body in the event of a frontal impact.
- 2.8. 'Strap' means a flexible component designed to transmit forces;
- 2.8.1. 'lap strap' means a strap which, either in the form of a complete belt or in the form of a component of such a belt, passes across the front of, and restrains, the child's pelvic region;
- 2.8.2. 'shoulder restraint' means that part of a belt which restrains the child's upper torso;
- 2.8.3. 'crotch strap' means a strap (or divided straps, where two or more pieces of webbing make it) attached to the child restraint and the lap strap and is so positioned as to pass between the child's thighs; it is designed to prevent the child sliding under the lap belt in normal use and prevent the lap belt moving up off the pelvis in an impact.
- 2.8.4. 'child-restraining strap' means a strap which is a constituent part of the belt and restrains only the body of the child;
- 2.8.5. 'child-restraint attachment strap' means a strap which attaches the child restraint to the structure of the vehicle and may be a part of the vehicle-seat retaining device;
- 2.8.6. 'harness belt' means a belt assembly comprising a lap belt, shoulder restraints and, where fitted, a crotch strap;

- 2.8.7. 'Y-shaped belt' means a belt where the combination of straps is formed by a strap to be guided between the child's legs and a strap for each shoulder.
- 2.9. 'Buckle' means a quick release device which enables the child to be held by the restraint or the restraint by the structure of the car and can be quickly opened. The buckle may incorporate the adjusting device;
- 2.9.1. 'enclosed buckle release button', a buckle release button such that it must not be possible to release the buckle using a sphere having a diameter of 40 mm;
- 2.9.2. 'non-enclosed buckle release button', a buckle release button such that it must be possible to release the buckle using a sphere having a diameter of 40 mm.
- 2.10. 'Adjusting device' means a device enabling the restraint or its attachments to be adjusted to the physique of the wearer, the configuration of the vehicle, or both. The adjusting device may either be part of the buckle or be a retractor or any other part of the safety belt;
- 2.10.1. 'quick adjuster' means an adjusting device which can be operated by one hand in one smooth movement.
- 2.10.2. 'adjuster mounted directly on child restraint' means an adjuster for the integral harness which is directly mounted on the child restraint, as opposed to being directly supported by the webbing that it is designed to adjust.
- 2.11. 'Attachments' means parts of the child restraint, including securing components, which enable the child restraint to be firmly secured to the vehicle structure either directly or through the vehicle seat.
- 2.12. 'Energy absorber' means a device which is designed to dissipate energy independently of or jointly with the strap and forms part of a child restraint.
- 2.13. 'Retractor' means a device designed to accommodate a part or the whole of the strap of a child restraint. The term covers the following devices:
- 2.13.1. 'an automatically-locking retractor', a retractor which allows extraction of the desired length of a strap and, when the buckle is fastened, automatically adjusts the strap to the wearer's physique, further extraction of the strap without voluntary intervention by the wearer being prevented;
- 2.13.2. 'an emergency-locking retractor', a retractor which does not restrict the belt wearer's freedom of movement in normal

driving conditions. Such a device has length-adjusting devices which automatically adjust the strap to the wearer's physique, and a locking mechanism actuated in an emergency by:

- 2.13.2.1. deceleration of the vehicle, extraction of the strap from the retractor, or any other automatic means (single sensitivity); or
- 2.13.2.2. a combination of any of these means (multiple sensitivity).
- 2.14. 'Restraint anchorages' means these parts of the vehicle structure or seat structure to which the child-restraint attachments are secured;
 - 2.14.1. 'additional anchorage' means a part of the vehicle structure or of the vehicle seat structure, or any other part of the vehicle, to which a child restraint is intended to be secured and which is additional to the anchorages approved under Regulation No. 14.
- 2.15. 'Forward-facing' means facing in the normal direction of travel of the vehicle.
- 2.16. 'Rearward-facing' means facing in the direction opposite to the normal direction of travel of the vehicle.
- 2.17. 'Inclined position' means a special position of the chair which allows the child to recline.
- 2.18. 'Lying down/supine/prone position' means a position where at least the child's head and body excluding its limbs are on a horizontal surface when at rest in the restraint.
- 2.19. 'Child-restraint type' means child restraints which do not differ in such essential respects as:
 - 2.19.1. the category, and the mass group(s) for which and the position and orientation (as defined in paragraphs 2.15. and 2.16.) in which the restraint is intended to be used;
 - 2.19.2. the geometry of the child restraint;
 - 2.19.3. the dimensions, mass, material and colour of:
 - the seat;
 - the padding; and
 - the impact shield;
 - 2.19.4. the material, weave, dimensions and colour of the straps;
 - 2.19.5. the rigid components (buckle, attachments, etc.).
- 2.20. 'Vehicle seat' means a structure, which may or may not be integral with the vehicle structure, complete with trim and

intended to seat one adult person. In this respect:

- 2.20.1. 'group of vehicle seats' means either a bench seat or a plurality of seats which are separate but side by side (i.e. so fixed that the front anchorages of one seat are in line with the front or rear anchorages of another seat or on a line passing between those anchorages), each seat accommodating one or more seated adult persons;
- 2.20.2. 'vehicle bench seat' means a structure complete with trim and intended to seat more than one adult person;
- 2.20.3. 'vehicle front seats' means the group of seats situated foremost in the passenger compartment, i.e. having no other seat directly in front of them;
- 2.20.4. 'vehicle rear seats' are fixed, forward-facing seats situated behind another group of vehicle seats.
- 2.21. 'Adjustment system' means the complete device by which the vehicle seat or its parts can be adjusted to suit the physique of the seat's adult occupant; this device may, in particular, permit:
 - 2.21.1. longitudinal displacement, and/or
 - 2.21.2. vertical displacement, and/or
 - 2.21.3. angular displacement.
- 2.22. 'Vehicle seat anchorage' means the system, including the affected parts of the vehicle structure, by which the adult seat as a whole is secured to the vehicle structure.
- 2.23. 'Seat type' means a category of adult seats which do not differ in such essential respects as:
 - 2.23.1. the shape, dimensions and materials of the seat structure,
 - 2.23.2. the types and dimensions of the seat-look adjustment and looking systems, and
 - 2.23.3. the type and dimensions of the adult safety-belt anchorage on the seat, of the seat anchorage, and of the affected parts of the vehicle structure.
- 2.24. 'Displacement system' means a device enabling the adult seat or one of its parts to be displaced angularly or longitudinally, without a fixed intermediate position, to facilitate the entry and exit of passengers and the loading and unloading of objects.
- 2.25. 'Locking system' means a device ensuring that the adult seat

and its parts are maintained in the position of use.

2.26. "Lock-off device" is a device which locks and prevents movement of one section of the webbing of an adult safety-belt relative to another section of the webbing of the same belt. The term covers the following classes:

2.26.1. "Class A device", a device that prevents the child pulling webbing from the retractor through to the lap part of the belt, when the adult belt is used to restrain the child directly. When supplied with group I restraints, the device allows compliance with paragraph 6.2.9.

2.26.2. "Class B device", a device that allows the retention of an applied tension in the lap part of an adult safety-belt, when the adult belt is used to restrain the child restraint. The device is intended to prevent webbing slipping from the retractor through the device, which would release the tension and place the restraint in a non-optimal position.

2.27. "Special Needs Restraint" is a child restraint system designed for children who have special needs as a result of either a physical or mental handicap; this device may in particular permit additional restraining devices for any part of the child, but it must contain as a minimum a primary means of restraint which complies with the requirements of this Regulation.

3. APPLICATION FOR APPROVAL

3.1. The application for approval of a type of child restraint shall be submitted by the holder of the trade mark or by his duly accredited representative.

3.2. The application for approval, relating to each type of child restraint, shall be accompanied by:

3.2.1. a technical description of the child restraint, specifying the straps and other materials used, and accompanied by drawings of the parts making up the child restraint and in the case of retractors, installation instructions for these retractors and their sensing devices, declaration on toxicity (paragraph 6.1.5.) and flammability (paragraph 6.1.6.), the drawings must show the position intended for the approval number and additional symbol(s) in relation to the circle of the approval mark. The description shall mention the colour of the model submitted for approval;

3.2.2. four samples of the child restraint;

3.2.3. a 10-metre length of each category of strap used in the child restraint; and

- 3.2.4. additional samples shall be supplied at the request of the technical service responsible for conducting the test;
- 3.2.5. instructions and details of packaging in accordance with paragraph 14. below;
- 3.2.6. in case of carry-cots, if the carry-cot restraint may be used in combination with a number of types of carry-cots, the restraint manufacturer shall supply a list of the latter.
- 3.3. Where an approved adult safety belt is used to secure the child restraint, the application must stipulate the category of adult safety belt to be used, e.g. static lap belts.
- 3.4. The competent authority shall verify the existence of satisfactory arrangements for ensuring effective control of conformity of production before type-approval is granted.
4. MARKINGS
- 4.1. The samples of child restraint submitted for approval in conformity with the provisions of paragraphs 3.2.2. and 3.2.3. above shall be clearly and indelibly marked with the manufacturer's name, initials or trade mark.
- 4.2. One of the parts made of plastics of the child restraint device (such as shell, impact shield, booster cushion, etc.), except the belt(s) or harness, shall be marked clearly (and indelibly) with the year of production.
- 4.3. If the restraint is to be used in combination with an adult safety belt the correct routing of the webbing shall be clearly indicated by means of a drawing permanently attached to the restraint. If the restraint is held in place by the adult safety-belt, the routes of the webbing shall be clearly marked on the product by colour coding. The colours for the safety-belt route to be used when the device is installed forward facing shall be red and when installed rear-facing shall be blue. The same colours shall also be used on the labels on the device that illustrate the methods of use.
- The separate routes of the lap and shoulder sections of the safety-belt shall each be distinguished on the product by colour coding and/or words.
- The marking defined in this paragraph shall be visible with the restraint in the vehicle. For group 0 restraints, this marking shall also be visible with the child in the restraint.
- 4.4. Rearward facing child restraints shall have a permanently attached label, visible in the installed position, with the warning: "EXTREME HAZARD - Do not use in passenger seats equipped with airbags"; this label shall be provided in the

language of the country where the device is sold.

4.5.

In the case of child restraints that can be used forward and rear-facing, include the words:

"IMPORTANT - DO NOT USE FORWARD FACING BEFORE THE CHILD'S WEIGHT EXCEEDS (Refer to instructions)"

5. APPROVAL
- 5.1. Each sample submitted in conformity with paragraphs 3.2.2. and 3.2.3. above shall meet the specifications set forth in paragraphs 6. to 8. of this Regulation in every respect before approval can be granted.
- 5.2. An approval number shall be assigned to each type approved. Its first two digits (at present 03 corresponding to the 03 series of amendments which entered into force on 12 September 1995) shall indicate the series of amendments incorporating the most recent major technical amendments made to the Regulation at the time of issue of the approval. The same Contracting Party shall not assign the same number to another type of child restraint covered by this Regulation.
- 5.3. Notice of approval or of extension or refusal of approval of a child restraint pursuant to this Regulation shall be communicated to the Parties to the Agreement which apply this Regulation by means of a form conforming to the model in annex 1 to this Regulation.
- 5.4. In addition to the marks prescribed in paragraph 4. above, the following particulars shall be affixed in a suitable space to every child restraint conforming to a type approved under this Regulation:
- 5.4.1. an international approval mark consisting of:
- 5.4.1.1. a circle surrounding the letter "E" followed by the distinguishing number of the country which has granted approval; 1/
- 5.4.1.2. an approval number;
- 5.4.2. the following additional symbols:

1/ 1 for Germany, 2 for France, 3 for Italy, 4 for the Netherlands, 5 for Sweden, 6 for Belgium, 7 for Hungary, 8 for the Czech Republic, 9 for Spain, 10 for Yugoslavia, 11 for the United Kingdom, 12 for Austria, 13 for Luxembourg, 14 for Switzerland, 15 (vacant), 16 for Norway, 17 for Finland, 18 for Denmark, 19 for Romania, 20 for Poland, 21 for Portugal, 22 for the Russian Federation, 23 for Greece, 24 (vacant), 25 for Croatia, 26 for Slovenia, 27 for Slovakia, 28 for Belarus, 29 for Estonia, 30 (vacant), 31 for Bosnia and Herzegovina, 32-36 (vacant) and 37 for Turkey. Subsequent numbers shall be assigned to other countries in the chronological order in which they ratify the Agreement concerning the Adoption of Uniform Conditions of Approval and Reciprocal Recognition of Approval for Motor Vehicle Equipment and Parts, or in which they accede to that Agreement, and the numbers thus assigned shall be communicated by the Secretary-General of the United Nations to the Contracting Parties to the Agreement.

- 5.4.2.1. the word(s) "universal", "restricted", "semi-universal" or "vehicle specific" depending on the category of restraint.
- 5.4.2.2. the mass range for which the child restraint has been designed, namely, less than 10 kg; less than 13 kg; 9-18 kg; 15-25 kg; 22-36 kg; less than 18 kg; 9-25 kg; 15-36 kg; less than 25 kg; 9-36 kg; less than 36 kg;
- 5.4.2.3. the symbol 'Y', in the case of a device containing a crotch strap, in conformity with the requirements of supplement 3 to the 02 series of amendments to the Regulation;
- 5.4.2.4. the symbol "S" in the case of a "Special Needs Restraint".
- 5.5. Annex 2 to this Regulation gives an example of the arrangement of the approval mark.
- 5.6. The particulars referred to in paragraph 5.4. above shall be clearly legible and be indelible, and may be affixed either by means of a label or by direct marking. The label or marking shall be resistant to wear.
- 5.7. The labels referred to in paragraph 5.6. above may be issued either by the authority which has granted the approval or, subject to that authority's authorization, by the manufacturer.
6. GENERAL SPECIFICATIONS
- 6.1. Positioning and securing on the vehicle
- 6.1.1. The use of child restraints in the "universal", "semi-universal" and "restricted" categories is permitted in the front and rear seat positions if the restraints are fitted in conformity with the manufacturer's instructions.
- 6.1.2. The use of child restraints in the "specific vehicle" category is permitted in all seat positions and also in the luggage area if the restraints are fitted in conformity with the manufacturer's instructions. In the case of a rear-facing restraint, the design must ensure that support for the child's head is provided whenever the restraint is ready to use.
- 6.1.3. According to the category which it belongs to, the child restraint shall be secured to the vehicle structure or to the seat structure;
- 6.1.3.1. for the "universal" and "restricted" categories, only by means of an adult safety-belt (with or without a retractor) meeting the requirements of Regulation No. 16 (or equivalent) fitted to anchorages meeting the requirements of Regulation No. 14 (or equivalent).
- 6.1.3.2. for the 'semi-universal' category: by means of the lower

anchorages prescribed in Regulation No. 14 and additional anchorages meeting the recommendation of annex 11 to this Regulation;

6.1.3.3. for the 'specific vehicle' category: by means of the anchorages designed by the manufacturer of the vehicle or the manufacturer of the child restraint;

6.1.3.4. In the case of child restraining straps or child restraint attachment strap utilizing belt anchorages to which are already fitted an adult belt or belts, the technical service shall check that:

The effective adult anchorage position is as approved under Regulation No. 14 or equivalent;

Effective operation of both devices is not hindered by the other;

The buckles of the adult and additional system must not be interchangeable.

In the case of child restraining devices utilizing bars, or extra devices attached to the anchorages approved under Regulation No. 14, which move the effective anchorage position outside the field of Regulation No. 14, the following points shall apply:

Such devices will only be approved as semi-universal or specific vehicle devices;

The technical service shall apply the requirements of annex 11 to this Regulation to the bar and the fastenings;

The bar will be included in the dynamic test, with the loading being applied to the mid-position and the bar and its greatest extension, if adjustable;

The effective position and operation of any adult anchorage by which the bar is fixed shall not be impaired.

6.1.4. A booster cushion must be restrained by either an adult belt or by separate means.

6.1.5. The child restraint manufacturer has to declare in written form that the toxicity of materials used in the manufacture of restraint systems and accessible to the restrained child is in conformity with the relevant parts of CEN Safety of Toys,

part 3 (June 1982). 2/ Tests confirming the validity of the declaration may be carried out at the discretion of the test authority. This paragraph does not apply to restraint devices of groups II and III.

6.1.6. The child restraint manufacturer has to declare in written form that the flammability of materials used to manufacture the restraint system is in conformity with the relevant paragraphs of the ECE Consolidated Resolution on the Construction of Vehicles (R.E.3) (document TRANS/WP.29/78/Rev.1, paragraph 1.42). Tests confirming the validity of the declaration may be carried out at the discretion of the test authority.

6.1.7. In the case of rearward-facing child restraints supported by the vehicle dashboard, for the purpose of approval to this Regulation the dashboard is assumed to be sufficiently rigid.

6.1.8. In the case of child restraints of the "universal" category, the main load-bearing contact point between the child restraint and the adult safety-belt shall not be less than 150 mm from the Cr axis when measured with the child restraint on the dynamic test bench. This shall apply to all adjustment configurations.

6.1.9. The maximum length of adult belt which may be used to secure a "universal" category child restraint on the dynamic test bench is defined in annex 13 to this Regulation.

To check compliance with this requirement, the child restraint shall be secured onto the test bench using the appropriate standard seat belt described in annex 13. The dummy shall not be installed unless the design of the restraint is such that the installation of a dummy would increase the amount of belt used. With the child restraint in the installed position there shall be no tension in the belt apart from that exerted by the standard retractor, where fitted. Where the retractor belt is used, this condition shall be met with at least 150 mm of belt remaining on the spool.

6.1.10. Child restraints of groups 0 and 0+ shall not be used forward facing.

6.2. Configuration

6.2.1. The configuration of the restraint shall be such that

6.2.1.1. the restraint gives the required protection in any intended position of the restraint system; for "Special Needs

2/ The address to obtain the relevant CEN standards is: CEN, 2 rue Bréderode, B.P. 5, B 1000 Bruxelles, Belgium.

Restraints" the primary means of restraint shall give the required protection in any intended position of the restraint system without the use of the additional restraining devices which may be present.

- 6.2.1.2. the child is easily and quickly installed and removed; in the case of a child restraint system in which the child is restrained by means of a harness belt or a Y-shaped belt without a retractor each shoulder restraint and lap strap shall be capable of movement relative to each other during the procedure prescribed in paragraph 7.2.1.4.

In these cases the belt assembly of the child restraint system may be designed with two or more connecting parts. For "Special Needs Restraints" it is recognized that the additional restraining devices will restrict the speed by which a child can be installed and removed. However, the additional devices shall be designed to release quickly so far as possible.

- 6.2.1.3. setting of the restraint in the inclined position, if possible, can be performed without manual readjustment of the straps. A deliberate hand-action is required in order to put the restraint in the inclined position;

- 6.2.1.4. the groups 0, 0+ and I restraint systems shall keep the child so positioned as to give the required protection even when the child is asleep;

- 6.2.1.5. to prevent submarining, either by impact or through restlessness, a crotch strap shall be required on all forward-facing group I restraints incorporating an integral harness belt system. With the crotch strap attached, and in its longest position if adjustable, it shall not be possible to adjust the lap strap to lie above the pelvis in either the 9 kg or the 15 kg dummy.

- 6.2.2. For groups I, II and III, all restraint devices utilizing a "lap strap" must positively guide the "lap strap" to ensure that the loads transmitted by the "lap strap" are transmitted through the pelvis.

- 6.2.3. All straps of the restraint shall be so placed that they cannot cause discomfort to the wearer in normal use or assume a dangerous configuration. The distance between the shoulder-straps in the vicinity of the neck should be at least the width of the neck of the appropriate manikin.

- 6.2.4. The assembly shall not subject weak parts of the child's body (abdomen, crotch, etc.) to excessive stresses. The design shall be such that compression loads shall not be imposed on the crown of the child's head in the event of a collision.

- 6.2.4.1. Y-shaped belts may only be used in rearward facing child

restraint systems.

- 6.2.5. The child restraint shall be so designed and installed as:
- 6.2.5.1. to minimize the danger of injury to the child or to other occupants of the vehicle through sharp edges or protrusions (as defined in Regulation No. 21, for example);
- 6.2.5.2. not to exhibit sharp edges or protrusions liable to cause damage to vehicle-seat covers or to occupant's clothing;
- 6.2.5.3. not to subject weak parts of the child's body (abdomen, crotch, etc.) to supplementary inertial forces it sets up;
- 6.2.5.4. to ensure that its rigid parts do not, at points where they are in contact with straps, exhibit sharp edges capable of abrading the straps.
- 6.2.6. Any part made separable to enable components to be fixed and detached shall be so designed as to avoid any risk of incorrect assembly and use so far as possible. "Special Needs Restraints" may have additional restraining devices; these shall be designed to avoid any risk of incorrect assembly and that their means of release and mode of operation is immediately obvious to a rescuer in an emergency.
- 6.2.7. Where the child restraint intended for group I, group II and groups I and II combined includes a chair back, the internal height of the latter, determined in accordance with the diagram in annex 12, shall be not less than 500 mm.
- 6.2.8. Only automatically-locking retractors or emergency-locking retractors may be used.
- 6.2.9. For devices intended for use in Group I it must not be possible for the child to easily slacken that part of the system that restrains the pelvis after the child has been installed; any device that is designed to obtain this must be permanently attached to the child restraint system.
- 6.2.10. A child restraint may be designed for use in more than one mass group and/or by more than one child, provided that it is able to satisfy the requirements laid down for each of the groups concerned. A child restraint in the "universal" category must meet the requirements of that category for all mass groups for which it has been approved.
- 6.2.11. Child restraints with retractor

In the case of a child restraint incorporating a retractor, the retractor shall have met the requirements of paragraph 7.2.3. below.

- 6.2.12. In case of booster cushions, the ease with which the straps and tongue of an adult belt pass through the fixture points must be examined. This goes particularly for booster cushions which are designed for the front seats of cars, which may have long semi-rigid stalks. The fixed buckle should not be allowed to pass through the fixture points of booster seats, or to permit a lie of belt completely different from that of the test-trolley.
- 6.2.13. If the child restraint is designed for more than one child, each restraint system shall be fully independent with regard to load transfer and adjustments.

6.2.14. The child restraints incorporating inflatable elements shall be so designed that the conditions of use (pressure, temperature, humidity) have no influence on their ability to comply with the requirements of this Regulation.

7. PARTICULAR SPECIFICATIONS

7.1. Provisions applicable to the assembled restraint

7.1.1. Resistance to corrosion

7.1.1.1. A complete child restraint, or the parts thereof that are liable to corrosion, shall be subject to the corrosion test specified in paragraph 8.1.1. below.

7.1.1.2. After the corrosion test as prescribed in paragraphs 8.1.1.1. and 8.1.1.2., no signs of deterioration likely to impair the proper functioning of the child restraint, and no significant corrosion, shall be visible to the unaided eye of a qualified observer.

7.1.2. Energy absorption

7.1.2.1. For all devices with backrests there shall be internal surfaces, defined in annex 18 to this Regulation, comprising material with a peak acceleration of less than 60 g when measured in accordance with annex 17 to this Regulation. This requirement applies also to areas of impact shields which are in the head strike area.

7.1.3. Overturning

7.1.3.1. The child restraint shall be tested as prescribed in paragraph 8.1.2.; the manikin shall not fall out of the device and, when the test seat is in the upside down position the manikin's head shall not move more than 300 mm from its original position in a vertical direction relative to the test seat.

7.1.4. Dynamic test

7.1.4.1. General. The child restraint shall be subjected to a dynamic test in conformity with paragraph 8.1.3. below.

7.1.4.1.1. Child restraints of the "universal", "restricted" and "semi-universal" categories shall be tested on the test trolley by means of the test seat prescribed in paragraph 6, and in conformity with paragraph 8.1.3.1.

7.1.4.1.2. Child restraints of the "specific vehicle" category shall be tested with each vehicle model for which the child restraint is intended. The technical service responsible for conducting the test may reduce the number of vehicle models tested if they do

not differ greatly in the aspects listed in paragraph 7.1.4.1.2.3. The child restraint may be tested in one of the following ways:

- 7.1.4.1.2.1. On a complete vehicle, as prescribed in paragraph 8.1.3.3.;
- 7.1.4.1.2.2. In a vehicle body shell on the test trolley, as prescribed in paragraph 8.1.3.2.; or,
- 7.1.4.1.2.3. In sufficient parts of the vehicle bodyshell to be representative of the vehicle structure and impact surfaces. If the child restraint is intended for use in the rear seat, these shall include the back of the front seat, the rear seat, the floor pan, the B and C pillars and the roof. If the child restraint is intended for use in the front seat, the parts shall include the dashboard, the A pillars, the windscreen, any levers or knobs installed in the floor or on a console, the front seat, the floor pan and the roof. Furthermore, if the child restraint is intended for use in combination with the adult safety belt, the parts shall include the appropriate adult belt(s). The technical service responsible for conducting the test may permit items to be excluded if they are found to be superfluous. Testing shall be as prescribed in paragraph 8.1.3.2.
- 7.1.4.1.3. The dynamic test shall be performed on child restraints which have not previously been under load.
- 7.1.4.1.4. During the dynamic tests, no part of the child restraint actually helping to keep the child in position shall break, and no buckles or locking system or displacement system shall release.
- 7.1.4.1.5. In the case of 'non-integral type' the seat belt used shall be the standard belt and its anchorage brackets prescribed in annex 13 to this Regulation. This does not apply to "specific vehicle" approvals where the actual belt of the vehicle shall be used.
- 7.1.4.1.6. If a "specific vehicle" child restraint system is installed in the area behind the rearmost forward facing adult seat positions (for example, the luggage area), one test with the largest dummy/dummies on a complete vehicle as prescribed in paragraph 8.1.3.3.3. shall be performed. The other tests, including the conformity of production, may be done as prescribed in paragraph 8.1.3.2., if the manufacturer so wishes.
- 7.1.4.1.7. In the case of a "Special Needs Restraint" every dynamic test specified by this Regulation for each mass group shall be performed twice: first, using the primary means of restraint and second, with all restraining devices in use. In these tests, special attention shall be given to the requirements in

paragraphs 6.2.3. and 6.2.4.

- 7.1.4.1.8. During the dynamic tests, the standard safety-belt used to install the child restraint shall not become disengaged from any guide or locking device utilised for the test conducted.
- 7.1.4.2. Chest acceleration 3/
- 7.1.4.2.1. The resultant chest acceleration shall not exceed 55 g except during periods whose sum does not exceed 3 ms.
- 7.1.4.2.2. The vertical component of the acceleration from the abdomen towards the head shall not exceed 30 g except during periods whose sum does not exceed 3 ms.
- 7.1.4.3. Abdominal penetration 4/
- 7.1.4.3.1. During the verification described in annex 8 - appendix 1, paragraph 5.3., there shall be no visible signs of penetration of the modelling clay of the abdomen caused by any part of the restraining device.
- 7.1.4.4. Manikin displacement
- 7.1.4.4.1. Child restraints of the "universal", "restricted" and "semi-universal" categories:

3/ Chest acceleration limits do not apply when using the 'new born' manikin as it is not instrumented.

4/ The new-born manikin is not fitted with any abdominal insert. Therefore only a subjective analysis can be used as a guide to abdominal penetration.

- 7.1.4.4.1.1. Forward facing child restraints: the head of the manikin shall not pass beyond the planes BA and DA as defined in Figure 1 below.

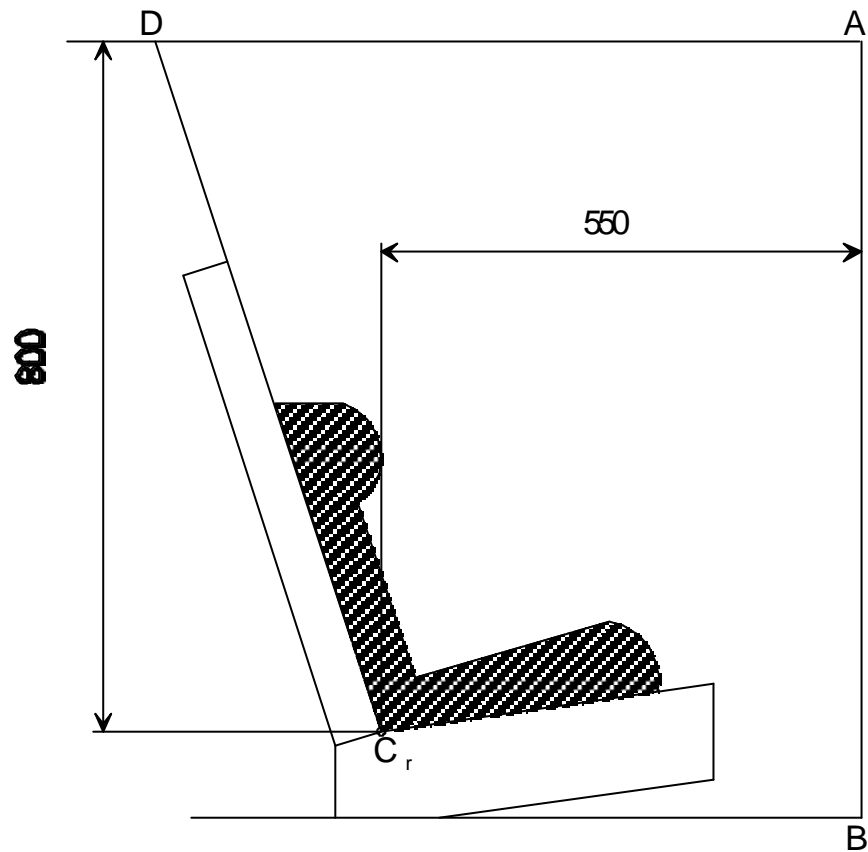

Dimensions in mm

Figure 1

Arrangement for testing a forward-facing device

7.1.4.4.1.2. Rear-facing child restraints:

7.1.4.4.1.2.1. Child restraints supported by dashboard: the head of the manikin shall not pass beyond the planes AD and DCr, as defined in Figure 2 below.

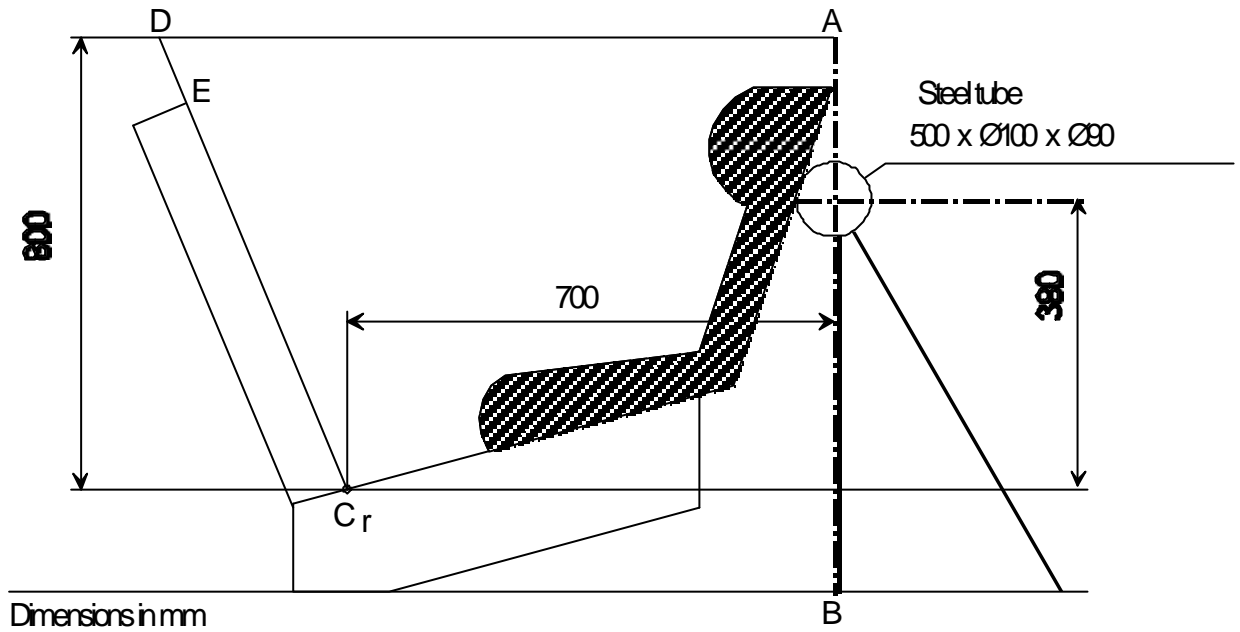

Figure 2
Arrangement for testing
a rearward-facing device

- 7.1.4.4.1.2.2. Child restraints in group 0 not supported by the dashboard, and carrycots: the head of the manikin shall not pass the planes AB, AD and DE as shown in Figure 3 below.

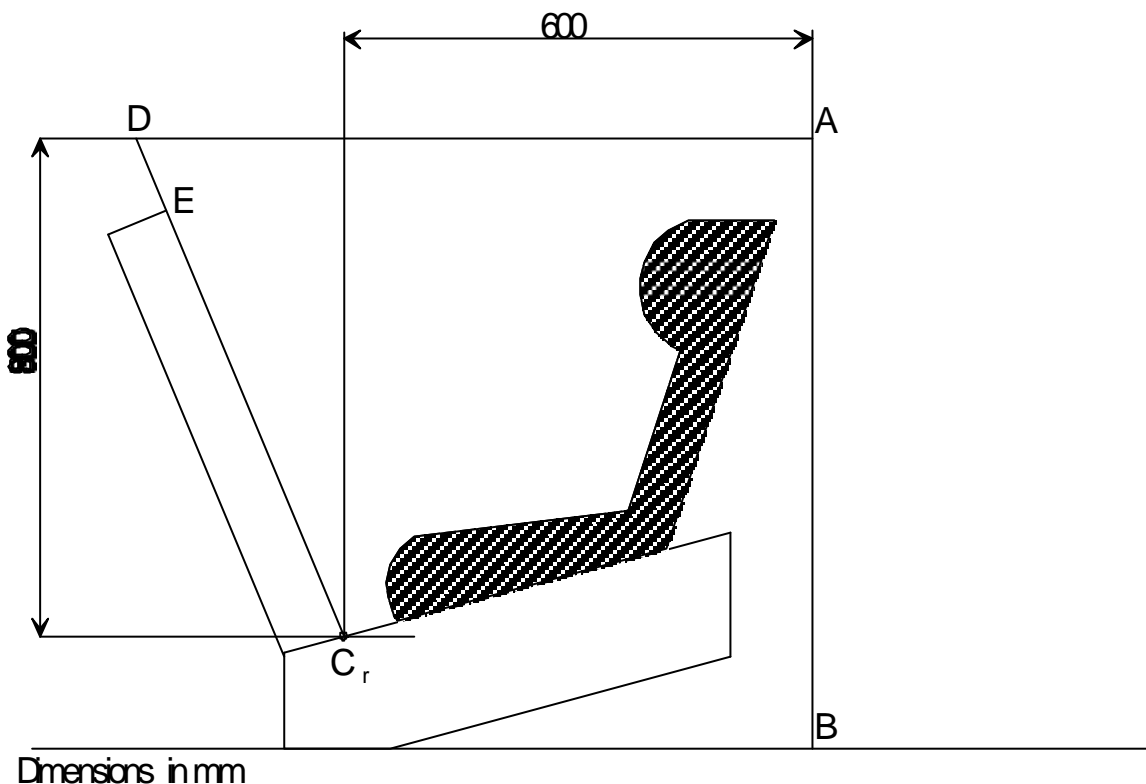

Figure 3

Arrangement for testing child restraint devices group 0,
not supported by the dashboard

- 7.1.4.4.1.2.3. Child restraints other than group 0 not supported by the dashboard:

The head of the manikin shall not pass the planes FD, FG and DE, as shown in Figure 4 below.

In the case there is a contact of such a child restraint with the 100 mm diameter bar and all performance criteria are met, there shall be one further dynamic test (front impact) with the heaviest dummy intended for such child restraint and without the 100 mm diameter bar; the requirements for this test are that all criteria other than forward displacement shall be met.

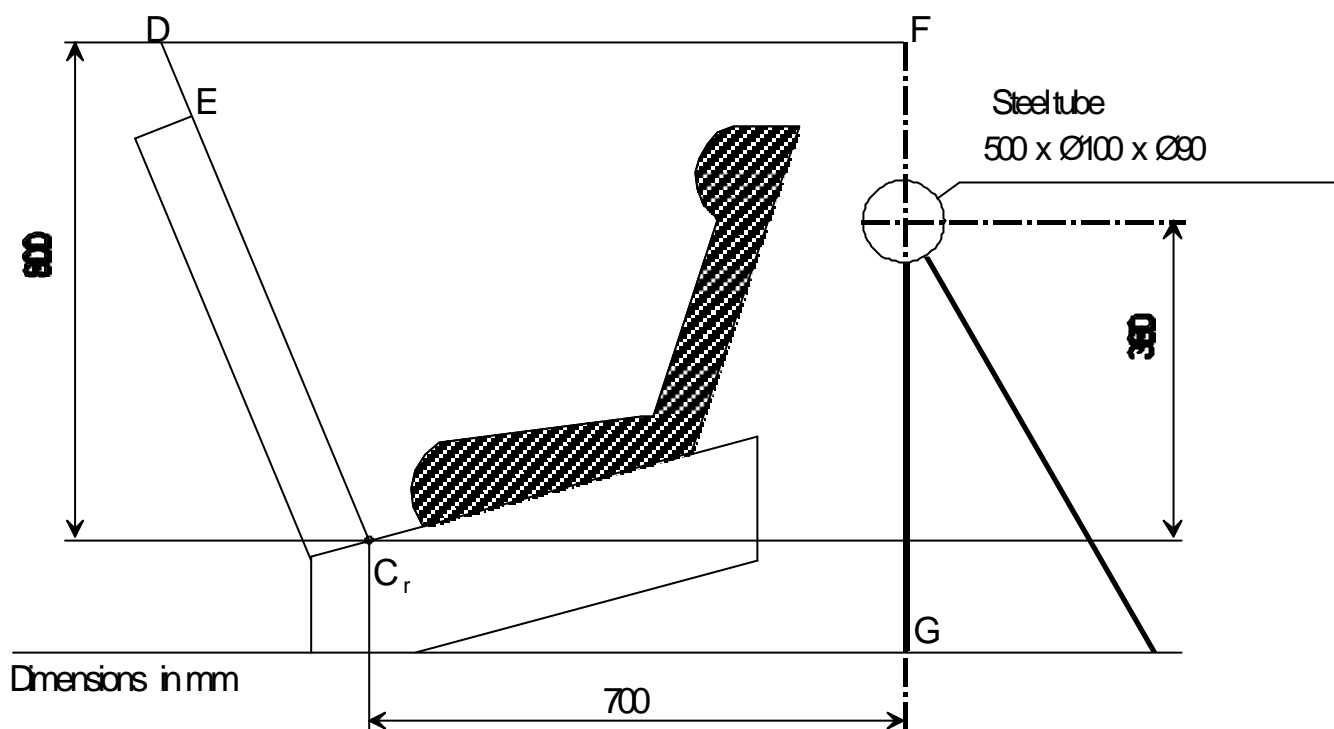

Figure 4:

Arrangement for testing rearward-facing devices, except group 0,
 not supported by the dashboard

7.1.4.4.2. Child restraints of the "specific vehicle" category: when tested in a complete vehicle or a vehicle body shell, the head shall not come into contact with any part of the vehicle. However, if there is contact, the speed of impact of the head shall be less than 24 km/h and the part contacted shall meet the requirements of the energy absorption test laid down in Regulation No. 21, annex 4. In tests with complete vehicles it shall be possible to remove the manikins from the child restraint without the use of tools after the test.

7.2. Provisions applicable to individual components of the restraint

7.2.1. Buckle

7.2.1.1. The buckle shall be so designed as to preclude any possibility of incorrect manipulation. This means,

inter/alia, that it must not be possible for the buckle to be left in a partially closed position; it must not be possible to exchange the buckle parts inadvertently when the buckle is being locked; the buckle must only lock when all parts are engaged. Wherever the buckle is in contact with the child, it shall not be narrower than the minimum width of strap as specified in paragraph 7.2.4.1.1 below. This paragraph is not applicable to belt assemblies already approved according to ECE Regulation No. 16 or any equivalent standard in force. In the case of a "Special Needs Restraint" only the buckle on the primary means of restraint need comply with the requirements of paragraphs 7.2.1.1. to 7.2.1.9. inclusive.

- 7.2.1.2. The buckle, even when not under tension, shall remain closed whatever its position. It shall be easy to operate and to grasp. It shall be possible to open it by pressure on a button or on a similar device. The surface to which this pressure must be applied must have in the position of actual unlocking: for enclosed devices, an area of not less than 4.5 cm² with a width of not less than 15 mm; for non-enclosed devices, an area of 2.5 cm² and a width of not less than 10 mm.
- 7.2.1.3. The buckle release area shall be coloured red. No other part of the buckle shall be of this colour.
- 7.2.1.4. It shall be possible to release the child from the restraint by a single operation on a single buckle. For groups 0 and 0+ it is allowed to remove the child together with devices such as infant carrier/carry-cot/carry-cot restraints if the child restraint system can be released by operation of a maximum of two buckles.
- 7.2.1.4.1. A clip connection between the shoulder straps of a harness belt is deemed not to comply with the single operation requirement given in paragraph 7.2.1.4. above.
- 7.2.1.5. For groups II and III the buckle shall be so placed that the child occupant can reach it. In addition it shall for all groups be so placed that its purpose and mode of operation are immediately obvious to a rescuer in an emergency.
- 7.2.1.6. Opening of the buckle shall enable the child to be removed independently of the "chair", "chair support" or "impact shield", if fitted, and if the device includes a crotch strap the crotch strap shall be released by operation of the same buckle.
- 7.2.1.7. The buckle shall be capable of withstanding repeated operation and shall, before the dynamic test prescribed in paragraph 8.1.3. undergo a test comprising 5,000 ± 5

opening and closing cycles under normal conditions for use.

- 7.2.1.8. The buckle shall be subjected to the following tests of opening:
- 7.2.1.8.1. Test under load
- 7.2.1.8.1.1. A child restraint having already undergone the dynamic test prescribed in paragraph 8.1.3. below shall be used for this test.
- 7.2.1.8.1.2. The force required to open the buckle in the test prescribed in paragraph 8.2.1.1. below shall not exceed 80 N.
- 7.2.1.8.2. No-load test
- 7.2.1.8.2.1. A buckle which has not previously been subjected to a load shall be used for this test. The force needed to open the buckle when it is not under load shall be in the range of 40-60 N in the tests prescribed in paragraph 8.2.1.2. below.
- 7.2.1.9. Strength.
- 7.2.1.9.1. During the test in accordance with paragraph 8.2.1.3.2. no part of the buckle or the adjacent straps or adjusters shall break or be detached.
- 7.2.1.9.2. A harness buckle of mass groups 0 and 0+ shall withstand 4,000 N.
- 7.2.1.9.3. A harness buckle of mass group I and higher shall withstand 10,000 N.
- 7.2.1.9.4. The competent authority may dispense with the buckle strength test if information already available renders the test superfluous.
- 7.2.2. Adjusting device
- 7.2.2.1. The range of adjustment shall be sufficient to permit correct adjustment of the child restraint throughout the weight group for which the device is intended and to permit satisfactory installation in all specified vehicle models.
- 7.2.2.2. All adjusting devices shall be of the "quick adjuster" type, except that adjusting devices used only for the initial installation of the restraint in the vehicle may be of other than the "quick adjuster" type.
- 7.2.2.3. Devices of the "quick adjuster" type shall be easy to reach

when the child restraint is correctly installed and the child or manikin is in position.

7.2.2.4. A device of the "quick adjuster" type shall be easily adjustable to the child's physique. In particular, in a test performed in accordance with paragraph 8.2.2.1., the

force required to operate a manual adjusting device shall not exceed 50 N.

- 7.2.2.5. Two samples of the child-restraint adjusting devices shall be tested as prescribed in paragraph 8.2.3. below.
- 7.2.2.5.1. The amount of strap slip shall not exceed 25 mm for one adjusting device or 40 mm for all adjusting devices.
- 7.2.2.6. The device must not break or become detached when tested as prescribed in paragraph 8.2.2.1. below.
- 7.2.2.7. An adjuster mounted directly on the child restraint shall be capable of withstanding repeated operation and shall, before the dynamic test prescribed in paragraph 8.1.3. undergo a test comprising $5,000 \pm 5$ cycles as specified in paragraph 8.2.7.
- 7.2.3. Retractors
- 7.2.3.1. Automatically-locking retractors
- 7.2.3.1.1. The strap of a safety-belt equipped with an automatically-locking retractor shall not unwind by more than 30 mm between locking positions of the retractor. After a rearward movement of the wearer the belt must either remain in its initial position or return to that position automatically on subsequent forward movement of the wearer.
- 7.2.3.1.2. If the retractor is part of a lap belt, the retracting force of the strap shall be not less than 7 N as measured in the free length between the manikin and the retractor as prescribed in paragraph 8.2.4.1. below. If the retractor is part of a chest restraint, the retracting force of the strap shall be not less than 2 N or more than 7 N as similarly measured. If the strap passes through a guide or pulley, the retracting force shall be measured in the free length between the manikin and the guide or pulley. If the assembly incorporates a device, manually or automatically operated, that prevents the strap from being completely retracted, that device shall not be in operation when these measurements are effected.
- 7.2.3.1.3. The strap shall be repeatedly withdrawn from the retractor and allowed to retract, in the conditions prescribed in paragraph 8.2.4.2. below, until 5,000 cycles have been completed. The retractor shall then be subjected to the corrosion test described in paragraph 8.1.1. and the dust-resistance test described in paragraph 8.2.4.5. It shall then satisfactorily complete a further 5,000 cycles of withdrawal and retraction. After the above tests the retractor shall continue to operate correctly and to meet

the requirements of paragraphs 7.2.3.1.1. and 7.2.3.1.2. above.

7.2.3.2. Emergency-locking retractors

7.2.3.2.1. An emergency-locking retractor shall when tested as prescribed in paragraph 8.2.4.3. satisfy the conditions below:

7.2.3.2.1.1. It shall be locked when the deceleration of the vehicle reaches 0.45 g.

7.2.3.2.1.2. It shall not lock for strap accelerations of less than 0.8 g as measured in the axis of strap extraction.

7.2.3.2.1.3. It shall not lock when its sensing device is tilted by not more than 12E in any direction from the installation position specified by its manufacturer.

7.2.3.2.1.4. It shall lock when its sensing device is tilted by more than 27E in any direction from the installation position specified by its manufacturer.

7.2.3.2.2. Where the operation of a retractor depends on an external signal or power source, the design shall ensure that the retractor locks automatically upon failure or interruption of that signal or power source.

7.2.3.2.3. A multiple-sensitivity emergency-locking retractor shall meet the requirements set out above. In addition, if one of the sensitivity factors relates to strap extraction, locking must have occurred at a strap acceleration of 1.5 g as measured in the axis of strap extraction.

7.2.3.2.4. In the tests referred to in paragraphs 7.2.3.2.1.1. and 7.2.3.2.3. above, the amount of strap extraction occurring before the retractor locks shall not exceed 50 mm, starting at the length of unwinding specified in paragraph 8.2.4.3.1. In the test referred to in paragraph 7.2.3.2.1.2. above, locking shall not occur during the 50 mm of strap extraction starting at the length of unwinding specified in paragraph 8.2.4.3.1. below.

7.2.3.2.5. If the retractor is part of a lap belt, the retracting force of the strap shall be not less than 7 N as measured in the free length between the manikin and the retractor as prescribed in paragraph 8.2.4.1. If the retractor is part of a chest restraint, the retracting force of the strap shall be not less than 2 N or more than 7 N as similarly measured. If the strap passes through a guide or pulley, the retracting force shall be measured in the free length between the manikin and the guide or pulley. If the assembly incorporates a device, manually or automatically

operated, that prevents the strap from being completely retracted, that device shall not be in operation when these measurements are effected.

7.2.3.2.6. The strap shall be repeatedly withdrawn from the retractor and allowed to retract, in the conditions prescribed in paragraph 8.2.4.2., until 40,000 cycles have been completed. The retractor shall then be subjected to the corrosion test described in paragraph 8.1.1. and to the dust-resistance test described in paragraph 8.2.4.5. It shall then satisfactorily complete a further 5,000 cycles of withdrawal and retraction (making 45,000 in all). After the above tests the retractor shall continue to operate correctly and to meet the requirements of paragraphs 7.2.3.2.1. to 7.2.3.2.5. above.

7.2.4. Straps

7.2.4.1. Width

7.2.4.1.1. The minimum width at the child-restraint straps which contact the dummy shall be 25 mm for groups 0, 0+ and I, and 38 mm for groups II and III. These dimensions shall be measured during the strap strength test prescribed in paragraph 8.2.5.1., without stopping the machine and under a load equal to 75 per cent of the breaking load of the strap.

7.2.4.2. Strength after room conditioning

7.2.4.2.1. On two sample straps conditioned as prescribed in paragraph 8.2.5.2.1., the breaking load of the strap shall be determined as prescribed in paragraph 8.2.5.1.2. below.

7.2.4.2.2. The difference between the breaking loads of the two samples shall not exceed 10 per cent of the greater of the two breaking loads measured.

7.2.4.3. Strength after special conditioning

7.2.4.3.1. On two straps conditioned as prescribed in one of the provisions of paragraph 8.2.5.2. (except paragraph 8.2.5.2.1.), the breaking load of the strap shall be not less than 75 per cent of the average of the loads determined in the test referred to in paragraph 8.2.5.1. below.

7.2.4.3.2. In addition, the breaking load shall be not less than 3.6 kN for the restraints of the groups 0, 0+ and I, 5 kN for those of group II, and 7.2 kN for those of group III.

7.2.4.3.3. The competent authority may dispense with one or more of these tests if the composition of the material used, or

information already available, renders the test or tests superfluous.

7.2.4.3.4. The abrasion conditioning procedure of type 1 defined in paragraph 8.2.5.2.6. shall only be performed when the microslip test defined in paragraph 8.2.3. below gives a result above 50 per cent of the limit prescribed in paragraph 7.2.2.5.1. above.

7.2.4.4. It shall not be possible to pull the complete strap through any adjusters, buckles or anchoring points.

7.2.5. Lock-off device

7.2.5.1. The lock-off device must be permanently attached to the child restraint.

7.2.5.2. The lock-off device must not impair the durability of the adult belt.

7.2.5.3. The lock-off device must not prevent the rapid release of the child.

7.2.5.4. Class A devices.

The amount of slip of the webbing shall not exceed 25 mm after the test prescribed in paragraph 8.2.6.1. below.

7.2.5.5. Class B devices.

The amount of slip of the webbing shall not exceed 25 mm after the test prescribed in paragraph 8.2.6.2. below.

8. DESCRIPTION OF TESTS \pm /

8.1. Tests of the assembled restraint

8.1.1. Corrosion

\pm / Tolerances on dimensions unless otherwise stated, not valid for boundaries

Range of dimensions (mm)	less than 6	above 6 to 30	above 30 to 120	above 120 to 315	above 315 to 1000	above 1000
Tolerance (mm)	\pm 0.5	\pm 1	\pm 1.5	\pm 2	\pm 3	\pm 4

Angular tolerances unless otherwise stated: \pm 1E

8.1.1.1. The metal items of the child restraint shall be positioned in a test chamber as prescribed in annex 4. In the case of a child restraint incorporating a retractor, the strap shall be unwound to full length less 100 ± 3 mm. Except for short interruptions that may be necessary, for example, to check and replenish the salt solution, the exposure test shall proceed continuously for a period of 50 ± 0.5 hours.

8.1.1.2. On completion of the exposure test the metal items of the child restraint shall be gently washed, or dipped, in clean running water with a temperature not higher than 38EC to remove any salt deposit that may have formed and then allowed to dry at room temperature of 18 to 25EC for 24 ± 1 hours before inspection in accordance with paragraph 7.1.1.2. above.

8.1.2. Overturning

8.1.2.1. The manikin shall be placed in the restraints installed in accordance with this Regulation and taking into account the manufacturer's instructions and with the standard slack as specified in paragraph 8.1.3.6. below.

8.1.2.2. The restraint shall be fastened to the test seat or vehicle seat. The whole seat shall be rotated around a horizontal axis contained in the median longitudinal plane of the seat through an angle of 360E at a speed of 2-5 degrees/second. For the purposes of this test, devices intended for use in specific cars may be attached to the test seat described in annex 6.

8.1.2.3. This test shall be carried out again rotating in the reverse direction after having replaced, if necessary, the manikin in its initial position. With the rotational axis in the horizontal plane and at 90E to that of the two earlier tests, the procedure shall be repeated in the two directions of rotation.

8.1.2.4. These tests shall be carried out using both the smallest and the largest appropriate manikin of the group or groups for which the restraining device is intended.

8.1.3. Dynamic tests

8.1.3.1. Tests on the trolley and test seat

8.1.3.1.1. Forward-facing

8.1.3.1.1.1. The trolley and test seat used in the dynamic test shall meet the requirements of annex 6 to this Regulation, and the dynamic crash test installation procedure is to be in accordance with annex 21.

- 8.1.3.1.1.2. The trolley shall remain horizontal throughout deceleration.
- 8.1.3.1.1.3. The deceleration of the trolley shall be achieved by using the apparatus prescribed in annex 6 to this Regulation or any other device giving equivalent results. This apparatus shall be capable of the performance specified in paragraph 8.1.3.4. and annex 7 of this Regulation.
- 8.1.3.1.1.4. The following measurements shall be made:
 - 8.1.3.1.1.4.1. the trolley speed immediately before impact;
 - 8.1.3.1.1.4.2. the stopping distance;
 - 8.1.3.1.1.4.3. the displacement of the manikin's head in the vertical and horizontal planes for groups I, II and III and for groups 0 and 0+ the displacement of the manikin without considering its limbs;
 - 8.1.3.1.1.4.4. the chest acceleration in three mutually perpendicular directions except for new-born manikin;
 - 8.1.3.1.1.4.5. any visible signs of penetration of the modelling clay in the abdomen (see paragraph 7.1.4.3.1.) except for new-born manikin.
- 8.1.3.1.1.5. After impact, the child restraint shall be inspected visually, without opening the buckle, to determine whether there has been any failure or breakage.
- 8.1.3.1.2. Rearward-facing
 - 8.1.3.1.2.1. The test seat shall be rotated 180° when testing in compliance with the requirements of the rear impact test.
 - 8.1.3.1.2.2. When testing a rearward-facing child restraint intended for use in the front seating position, the vehicle fascia shall be represented by a rigid bar attached to the trolley in such a way that all the energy absorption takes place in the child restraint.
 - 8.1.3.1.2.3. The deceleration conditions shall satisfy the requirements of paragraph 8.1.3.4. below.
 - 8.1.3.1.2.4. The measurements to be made shall be similar to those listed in paragraphs 8.1.3.1.1.4. to 8.1.3.1.1.4.5. above.
 - 8.1.3.1.2.5. After impact, the child restraint shall be inspected visually without opening the buckle, to determine whether there has been any failure or breakage.

- 8.1.3.2. Test on trolley and vehicle body shell
- 8.1.3.2.1. Forward-facing
- 8.1.3.2.1.1. The method used to secure the vehicle during the test shall not be such as to strengthen the anchorages of the vehicle seats, adult safety belts and any additional anchorages required to secure the child restraint or to lessen the normal deformation of the structure. No part of the vehicle shall be present which, by limiting the movement of the manikin, would reduce the load imposed on the child restraint during the test. The parts of the structure eliminated may be replaced by parts of equivalent strength, provided they do not hinder the movement of the manikin.
- 8.1.3.2.1.2. A securing device shall be regarded as satisfactory if it produces no effect on an area extending over the whole width of the structure and if the vehicle or structure is blocked or fixed in front at a distance of not less than 500 mm from the anchorage of the restraint system. At the rear the structure shall be secured at a sufficient distance behind the anchorages to ensure that all requirements of paragraph 8.1.3.2.1.1. above are fulfilled.
- 8.1.3.2.1.3. The vehicle seat and child restraint shall be fitted and shall be placed in a position chosen by the technical service conducting approval tests to give the most adverse conditions in respect of strength, compatible with installing the manikin in the vehicle. The position of the vehicle seat-back and child restraint shall be stated in the report. The vehicle seat-back, if adjustable for inclination, shall be locked as specified by the manufacturer or, in the absence of any specification, at an actual seat-back angle as near as possible to 25°.
- 8.1.3.2.1.4. Unless the instructions for fitting and use require otherwise, the front seat shall be placed in the most forward normally used position for child restraints intended for use in the front seating position, and in the rearmost normally used position for child restraints intended for use in the rear seating position.
- 8.1.3.2.1.5. The deceleration conditions shall satisfy the requirements of paragraph 8.1.3.4. below. The test seat will be the seat of the actual vehicle.
- 8.1.3.2.1.6. The following measurements shall be made:
- 8.1.3.2.1.6.1. the trolley speed immediately before impact;
- 8.1.3.2.1.6.2. the stopping distance;

- 8.1.3.2.1.6.3. any contact of the manikin's head with the interior of the vehicle body shell;
- 8.1.3.2.1.6.4. the chest deceleration in three mutually perpendicular directions, except for new-born manikin;
- 8.1.3.2.1.6.5. any visible signs of penetration of the modelling clay in the abdomen (see paragraph 7.1.4.3.1.), except for new-born manikin.
- 8.1.3.2.1.7. After impact, the child restraint shall be inspected visually, without opening the buckle, to determine whether there has been any failure.
- 8.1.3.2.2. Rearward-facing
 - 8.1.3.2.2.1. For rear impact tests the vehicle body shell shall be rotated 180° on the test trolley.
 - 8.1.3.2.2.2. Same requirements as for frontal impact.
- 8.1.3.3. Test with complete vehicle
 - 8.1.3.3.1. The deceleration conditions shall satisfy the requirements of paragraph 8.1.3.4. below.
 - 8.1.3.3.2. For frontal impact tests the procedure shall be that set out in annex 9 to this Regulation.
 - 8.1.3.3.3. For rear impact tests the procedure shall be that set out in annex 10 to this Regulation.
 - 8.1.3.3.4. The following measurements shall be made:
 - 8.1.3.3.4.1. the speed of the vehicle/impactor immediately before impact;
 - 8.1.3.3.4.2. any contact of the manikin's head (in the case of group 0 the manikin without considering its limbs) with the interior of the vehicle;
 - 8.1.3.3.4.3. the chest acceleration in three mutually perpendicular directions, except for new-born manikin;
 - 8.1.3.3.4.4. any visible signs of penetration of the modelling clay in the abdomen (see paragraph 7.1.4.3.1.), except for new-born manikin.
 - 8.1.3.3.5. The front seats, if adjustable for inclination, shall be locked as specified by the manufacturer or, in the absence of any specification, at an actual seat-back angle as near as possible to 25°.

8.1.3.3.6. After impact, the child restraint shall be inspected visually, without opening the buckle, to determine whether there has been any failure or breakage.

8.1.3.4. The conditions for dynamic test are summarized in the table below:

Test	Restraint	FRONTAL IMPACT			REAR IMPACT		
		Speed (km/h)	Test pulse	Stopping distance during test (mm)	Speed (km/h)	Test pulse	Stopping distance during test (mm)
Trolley with test seat	Forward facing front and rear seats universal, semi-universal or restricted */	50+0 -2	1	650±50	-	-	-
	Rearward facing front and rear seats universal, semi-universal or restricted **/	50+0 -2	1	650±50	30+2 -0	2	275±25
Vehicle body on trolley	Forward facing */	50+0 -2	1 or 3	650±50	-	-	-
	Rearward facing */	50+2 -2	1 or 3	650±50	30+2 -0	2 or 4	275±25
Whole vehicle barrier test	Forward facing	50+0 -2	3	not specified	-	-	-
	Rearward facing	50+0 -2	3	not specified	30+2 -0	4	not specified

NOTE: All restraint systems for groups 0 and 0+ shall be tested according to 'Rearward-facing' conditions in frontal and rearwards impact.

LEGEND:

Test Pulse No. 1 - As prescribed in annex 7 - frontal impact.

Test Pulse No. 2 - As prescribed in annex 7 - rear impact.

Test Pulse No. 3 - Deceleration pulse of vehicle subjected to frontal impact.

Test Pulse No. 4 - Deceleration pulse of vehicle subjected to rear impact.

*/ During calibration, the stopping distance should be 650 ± 30 mm.

**/ During calibration, the stopping distance should be 275 ± 20 mm.

- 8.1.3.5. Child restraints incorporating the use of additional anchorages
 - 8.1.3.5.1. In the case of child restraints intended for use as specified in paragraph 2.1.2.3. and incorporating the use of additional anchorages, the requirement for a frontal impact test, in accordance with paragraph 8.1.3.4., shall be carried out as follows:
 - 8.1.3.5.2. For devices with short upper attachment straps, e.g. intended to be attached to the rear parcel shelf, the upper anchorage configuration on the test trolley shall be as prescribed in annex 6, appendix 3.
 - 8.1.3.5.3. For devices with long upper attachment straps, e.g. intended for use where there is no rigid parcel shelf and where the upper anchorage straps are attached to the vehicle floor, the anchorages on the test trolley shall be as prescribed in annex 6, appendix 3.
 - 8.1.3.5.4. For devices, intended for use in both configurations, the tests prescribed in paragraphs 8.1.3.5.2. and 8.1.3.5.3. shall be carried out with the exception that, in case of the test carried out in accordance with the requirements of paragraph 8.1.3.5.3. above, only the heavier manikin shall be used.
 - 8.1.3.5.5. For rearward-facing devices, the lower anchorage of configuration on the test trolley shall be as prescribed in annex 6, appendix 3.
 - 8.1.3.6. Test manikins
 - 8.1.3.6.1. The child restraint and manikins shall be installed in such a way that the requirements of paragraph 8.1.3.6.3. are met.
 - 8.1.3.6.2. The child restraint shall be tested using the manikins prescribed in annex 8 to this Regulation.
 - 8.1.3.6.3. Installation of the manikin
 - 8.1.3.6.3.1. For frontal impact with forward-facing devices and rear impact with rear-facing devices the manikin shall be placed in such a way that the gap is between the front of the manikin and the restraint; for forward impact with rear-facing devices the manikin shall be placed so that the gap is between the rear of the manikin and the restraint. In the case of carry-cots the manikin is placed in a straight horizontal position as close as possible to the centre line of the carry-cot.

8.1.3.6.3.2. Child restraint with a separately anchored chair:

Place the child chair on the test seat.

Place the manikin in the child chair.

Place a hinged board or a similar flexible device 2.5 cm thick and 6 cm wide between the manikin and the seatback of the chair. The board should follow as closely as possible the curvature of the chair and its lower end should be at the height of the manikin's hip joint.

Adjust the belt in accordance with the manufacturer's instructions, but to a tension of 250 ± 25 N above the adjuster force, with a deflection angle of the strap at the adjuster of $45 \pm 5^\circ$, or alternatively, the angle prescribed by the manufacturer.

Complete the installation of the child chair to the test seat in accordance with annex 21 to this Regulation.

Remove the flexible device.

8.1.3.6.3.3. The longitudinal plane passing through the centre line of the dummy shall be set midway between the two lower belt anchorages, however note shall also be taken of paragraph 8.1.3.2.1.3. In case of booster cushions to be tested with the manikin representing a 10-year-old child, the longitudinal plane passing through the centre line of the manikin shall be positioned 75 ± 5 mm to the left or right with regard to the point midway between the two lower belt anchorages.

8.1.3.6.3.4. In the case of devices requiring the use of a standard belt, the shoulder strap may be positioned on the manikin prior to the dynamic test by the use of a light-weight masking tape of sufficient width and length. In case of rearward facing devices the head may be held against the backrest of the restraint system using a light-weight masking tape of sufficient length and width.

8.1.3.7. Category of manikin to be used

8.1.3.7.1. Group 0 device: Test using the 'new-born' manikin and a manikin of 9 kg;

8.1.3.7.2. Group 0+ device: test using the new-born manikin and a manikin of 11 kg.

8.1.3.7.3. Group I device: Tests using a manikin of mass 9 kg and 15 kg respectively;

- 8.1.3.7.4. Group II device: Tests using a manikin of mass 15 kg and 22 kg respectively;
- 8.1.3.7.5. Group III device: Tests using a manikin of mass 22 kg and 32 kg respectively.
- 8.1.3.7.6. If the child restraint system is suitable for two or more mass groups, the tests shall be carried out using the lightest and heaviest manikins specified above for all the groups concerned. However, if the configuration of the device alters considerably from one group to the next, for instance when the configuration of the harness or the harness length is changed, the laboratory conducting the tests may, if it deems it advisable, add a test with a manikin of intermediate weight.
- 8.1.3.7.7. If the child restraint system is designed for two or more children, one test shall be carried out with the heaviest manikins occupying all seat positions. A second test with the lightest and the heaviest manikins specified above shall be carried out. The laboratory conducting the tests may, if it deems it advisable, add a third test with any combination of manikins or empty seat positions.
- 8.2. Tests of individual components
- 8.2.1. Buckle
- 8.2.1.1. Opening test under load
- 8.2.1.1.1. A child restraint already having been subjected to the dynamic test specified in paragraph 8.1.3. shall be used for this test.
- 8.2.1.1.2. The child restraint shall be removed from the test trolley or the vehicle without opening the buckle. A tension of 200 ± 2 N shall be applied to the buckle. If the buckle is attached to a rigid part, the force shall be applied reproducing the angle formed between the buckle and that rigid part during the dynamic test.
- 8.2.1.1.3. A load shall be applied at a speed of 400 ± 20 mm/min to the geometric centre of the buckle-release button along a fixed axis running parallel to the initial direction of motion of the button; the geometric centre applies to that part of the surface of the buckle to which the release pressure is to be applied. The buckle shall be secured against a rigid support during the application of the opening force.
- 8.2.1.1.4. The buckle opening force shall be applied, using a dynamometer or similar device in the manner and direction of normal use. The contact end shall be a polished metal hemisphere with radius 2.5 ± 0.1 mm.

- 8.2.1.1.5. The buckle opening force shall be measured and any failure noted.
- 8.2.1.2. Opening test under zero load
- 8.2.1.2.1. A buckle assembly which has not previously been subjected to a load shall be mounted and positioned under a "no load" condition.
- 8.2.1.2.2. The method of measuring the buckle opening force shall be as prescribed in paragraphs 8.2.1.1.3. and 8.2.1.1.4.
- 8.2.1.2.3. The buckle opening force shall be measured.
- 8.2.1.3. Strength test.
- 8.2.1.3.1 For the strength test two samples have to be used. All adjusters, except for adjusters mounted directly on a child restraint are included in the test.
- 8.2.1.3.2. Annex 20 shows a typical device for a buckle strength test. The buckle is placed on the upper round plate (A) within the relief. All adjacent straps have a length of at least 250 mm and are arranged hanging down from the upper plate respective to their position at the buckle. The free strap ends are then wound round the lower round plate (B) until they come out at the plate's inner opening. All straps have to be vertical between A and B. The round clamping plate (C) is then lightly clamped against the lower face of (B), still allowing a certain strap movement between them. With a small force at the tensile machine the straps are tensioned and pulled between (B) and (C) until all straps are loaded respective to their arrangement. The buckle must stay free from plate (A) or any parts at (A) during this operation and the test itself. (B) and (C) are then clamped firmly together and the tensile force is increased at a traverse speed of 100 ± 20 mm/min until the required values are reached.
- 8.2.2. Adjusting device
- 8.2.2.1. Ease of adjustment
- 8.2.2.1.1. When testing a manual adjusting device, the strap shall be drawn steadily through the adjusting device, having regard for the normal conditions of use, at a rate of 100 ± 20 mm/min and the maximum force measured to the nearest integer value of N after the first 25 ± 5 mm of strap movement.
- 8.2.2.1.2. The test shall be carried out in both directions of strap travel through the device, the strap being subjected to the

full travel cycle 10 times prior to the measurement.

- 8.2.3. Microslip test (see annex 5, figure 3)
- 8.2.3.1. The components or devices to be subjected to the microslip test shall be kept for a minimum of 24 hours before testing in an atmosphere having a temperature of $20 \pm 5^{\circ}\text{C}$ and a relative humidity of 65 ± 5 per cent. The test shall be carried out at a temperature between 15 and 30°C .
- 8.2.3.2. The free end of the strap shall be arranged in the same configuration as when the device is in use in the vehicle, and shall not be attached to any other part.
- 8.2.3.3. The adjusting device shall be placed on a vertical piece of strap one end of which bears a load of 50 ± 0.5 N (guided in a manner which prevents the load from swinging and the strap from twisting). The free end of the strap from the adjusting device shall be mounted vertically upwards or downwards as it is in the vehicle. The other end shall pass over a deflector roller with its horizontal axis parallel to the plane of the section of strap supporting the load, the section passing over the roller being horizontal.
- 8.2.3.4. The device being tested shall be arranged in such a way that its centre, in the highest position to which it can be raised, is 300 ± 5 mm from a support table, and the load of 50 N shall be 100 ± 5 mm from that support table.
- 8.2.3.5. 20 ± 2 pre-test cycles shall then be completed and $1,000 \pm 5$ cycles shall then be completed at a frequency of 30 ± 10 cycles per minute, the total amplitude being 300 ± 20 mm or as specified in paragraph 8.2.5.2.6.2. The 50 N load shall be applied only during the time corresponding to a shift of 100 ± 20 mm for each half period. Microslip shall be measured from the position at the end of the 20 pre-test cycles.
- 8.2.4. Retractor
- 8.2.4.1. Retracting force
- 8.2.4.1.1. The retracting forces shall be measured with the safety belt assembly, fitted to a manikin as for the dynamic test prescribed in paragraph 8.1.3. The strap tension shall be measured at the point of contact with (but just clear of) the manikin while the strap is being retracted at the approximate rate of 0.6 m/min.
- 8.2.4.2. Durability of retractor mechanism
- 8.2.4.2.1. The strap shall be withdrawn and allowed to retract for the

required number of cycles at a rate of not more than
30 cycles per minute. In the case of emergency-locking
retractors, a jolt to lock the retractor shall be introduced

at each fifth cycle. The jolts occur in equal numbers at each of five different extractions, namely, 90, 80, 75, 70 and 65 per cent of the total length of the strap on the retractor. However, where the length of the strap exceeds 900 mm the above percentages shall be related to the final 900 mm of strap which can be withdrawn from the retractor.

- 8.2.4.3. Locking of emergency-locking retractors
- 8.2.4.3.1. The retractor shall be tested once for locking, when the strap has been unwound to its full length less 300 ± 3 mm.
- 8.2.4.3.2. In the case of a retractor actuated by strap movement, the extraction shall be in the direction in which it normally occurs when the retractor is installed in a vehicle.
- 8.2.4.3.3. When retractors are being tested for sensitivity to vehicle accelerations, they shall be tested at the above extraction length in both directions along two mutually perpendicular axes which are horizontal if the retractors are to be installed in a vehicle as specified by the child restraint manufacturer. When this position is not specified, the testing authority shall consult the child restraint manufacturer. One of these test directions shall be chosen by the technical service conducting the approval tests to give the most adverse conditions with respect to actuation of the locking mechanism.
- 8.2.4.3.4. The design of the apparatus used shall be such that the required acceleration is given at an average rate of increase of acceleration of at least 25 g/s 5/.
- 8.2.4.3.5. For testing compliance with the requirements of paragraphs 7.2.3.2.1.3. and 7.2.3.2.1.4. the retractor shall be mounted on a horizontal table and the table tilted at a speed not exceeding 2E per second until locking has occurred. The test shall be repeated with tilting in other directions to ensure that the requirements are fulfilled.
- 8.2.4.4. Corrosion test
- 8.2.4.4.1. The corrosion test is described in paragraph 8.1.1. above.
- 8.2.4.5. Dust resistance test
- 8.2.4.5.1. The retractor shall be positioned in a test chamber as described in annex 3 to this Regulation. It shall be mounted in an orientation similar to that in which it is mounted in the vehicle. The test chamber shall contain dust as specified in paragraph 8.2.4.5.2. below. A length of

5/ $g = 9.81 \text{ m/s}^2$.

500 mm of the strap shall be extracted from the retractor and kept extracted, except that it shall be subjected to 10 complete cycles of retraction and withdrawal within one or two minutes after each agitation of the dust. For a period of five hours, the dust shall be agitated every 20 minutes for five seconds by compressed air free of oil and moisture at a gauge pressure of 5.5 ± 0.5 bars entering through an orifice 1.5 ± 0.1 mm in diameter.

8.2.4.5.2. The dust used in the test described in paragraph 8.2.4.5.1. shall consist of about 1 kg of dry quartz. The particle size distribution shall be as follows:

- (a) passing 150 μm aperture, 104 μm wire diameter: 99 to 100 per cent;
- (b) passing 105 μm aperture, 64 μm wire diameter: 76 to 86 per cent;
- (c) passing 75 μm aperture, 52 μm wire diameter: 60 to 70 per cent.

8.2.5. Static test for straps

8.2.5.1. Strap strength test

8.2.5.1.1. Each test shall be carried out on two new samples of strap, conditioned as specified in paragraph 7.2.4.

8.2.5.1.2. Each strap shall be gripped between the clamps of a tensile strength-testing machine. The clamps shall be so designed as to avoid breakage of the strap at or near them. The speed of traverse shall be 100 ± 20 mm/min. The free length of the specimen between the clamps of the machine at the start of the test shall be $200 \text{ mm} \pm 40 \text{ mm}$.

8.2.5.1.3. The tension shall be increased until the strap breaks and the breaking load noted.

8.2.5.1.4. If the strap slips or breaks at or within 10 mm of either of the clamps, the test shall be invalid and a new test shall be carried out on another specimen.

8.2.5.2. Samples out from straps, as referred to in paragraph 3.2.3., shall be conditioned as follows:

8.2.5.2.1. Room conditioning

8.2.5.2.1.1. The strap shall be kept for 24 ± 1 hours in an atmosphere having a temperature of $23 \pm 5^\circ\text{E}$ and a relative humidity of 50 ± 10 per cent. If the test is not carried out immediately after conditioning, the specimen shall be placed in a hermetically closed receptacle until the test begins. The breaking load shall be determined within five minutes

after removal of the strap from the conditioning atmosphere or from the receptacle.

8.2.5.2.2. Light conditioning

8.2.5.2.2.1. The provisions of Recommendation ISO/105-B02(1978), shall apply. The strap shall be exposed to light for the time necessary to produce fading of Standard Blue Dye No. 7 to a contrast equal to Grade 4 on the grey scale.

8.2.5.2.2.2. After exposure, the strap shall be kept for a minimum of 24 hours in an atmosphere having a temperature of $23\text{E} \pm 5\text{EC}$ and a relative humidity of 50 ± 10 per cent. The breaking load shall be determined within five minutes after the removal of the strap from the conditioning installation.

8.2.5.2.3. Cold conditioning

8.2.5.2.3.1. The strap shall be kept for a minimum of 24 hours in an atmosphere having a temperature of $23 \pm 5\text{EC}$ and a relative humidity of 50 ± 10 per cent.

8.2.5.2.3.2. The strap shall then be kept for 90 ± 5 minutes on a plain surface in a low-temperature chamber in which the air temperature is $-30 \pm 5\text{EC}$. It shall then be folded and the fold shall be loaded with a weight of 2 ± 0.2 kg previously cooled to $-30 \pm 5\text{EC}$. When the strap has been kept under load for 30 ± 5 minutes in the same low-temperature chamber, the weight shall be removed and the breaking load shall be measured within five minutes after removal of the strap from the low-temperature chamber.

8.2.5.2.4. Heat conditioning

8.2.5.2.4.1. The strap shall be kept for 180 ± 10 minutes in a heating-cabinet atmosphere having a temperature of $60 \pm 5\text{EC}$ and a relative humidity 65 ± 5 per cent.

8.2.5.2.4.2. The breaking load shall be determined within five minutes after removal of the strap from the heating cabinet.

8.2.5.2.5. Exposure to water

8.2.5.2.5.1. The strap shall be kept fully immersed for 180 ± 10 minutes in distilled water, at a temperature of $20 \pm 5\text{EC}$, to which a trace of wetting agent has been added. Any wetting agent suitable for the fibre being tested may be used.

8.2.5.2.5.2. The breaking load shall be determined within 10 minutes after removal of the strap from the water.

8.2.5.2.6. Abrasion conditioning

8.2.5.2.6.1. The components or devices to be submitted to the abrasion test shall be kept for a minimum of 24 hours before testing in an atmosphere having a temperature of $23\text{E} \pm 5\text{EC}$ and a relative humidity of 50 ± 10 per cent. The room temperature during the testing shall be between 15E and 30EC .

8.2.5.2.6.2. The table below sets out the general conditions for each test:

	Load (N)	Cycles per minute	Cycles (No.)
Type 1 procedure	10 ± 0.1	30 ± 10	$1,000 \pm 5$
Type 2 procedure	5 ± 0.05	30 ± 10	$5,000 \pm 5$

Where there is insufficient strap to test over 300 mm of shift, the test may be applied over a shorter length subject to a minimum of 100 mm.

8.2.5.2.6.3. Particular test conditions

8.2.5.2.6.3.1. Type 1 procedure: for cases where the strap slides through the quick adjusting device. The 10 N load shall be vertically and permanently applied on one of the straps. The other strap, set horizontally, shall be attached to a device, giving the webbing a back and forth motion. The adjusting device shall be so placed that the horizontal strap of the webbing remains under tension (see annex 5, figure 1).

8.2.5.2.6.3.2. Type 2 procedure: for cases where the strap changes direction in passing through a rigid part. During this test, the angles of both webbing straps shall be as shown in annex 5, figure 2. The 5 N load shall be permanently applied. For cases where the strap changes direction more than once in passing through a rigid part, the load of 5 N may be increased so as to achieve the prescribed 300 mm of strap movement through that rigid part.

8.2.6. Lock-off Devices

8.2.6.1. Class A Devices

The child restraint and the largest manikin for which the child restraint is intended shall be set up as shown in Figure 5 below. The webbing used shall be as specified in annex 13 to this Regulation. The lock-off shall be fully applied and a mark made on the belt where the belt enters the lock-off. The force gauges shall be attached to the belt via a D ring, and a force equal to twice (± 5 per cent)

the mass of the heaviest dummy of group I shall be applied for at least one second. The lower position shall be used for lock-offs in position A and the upper position for lock-offs in position B. The force shall be applied for a further 9 times. A further mark shall be made on the belt where it enters the lock-off and the distance between the two marks shall be measured. During this test, the retractor must be unlocked.

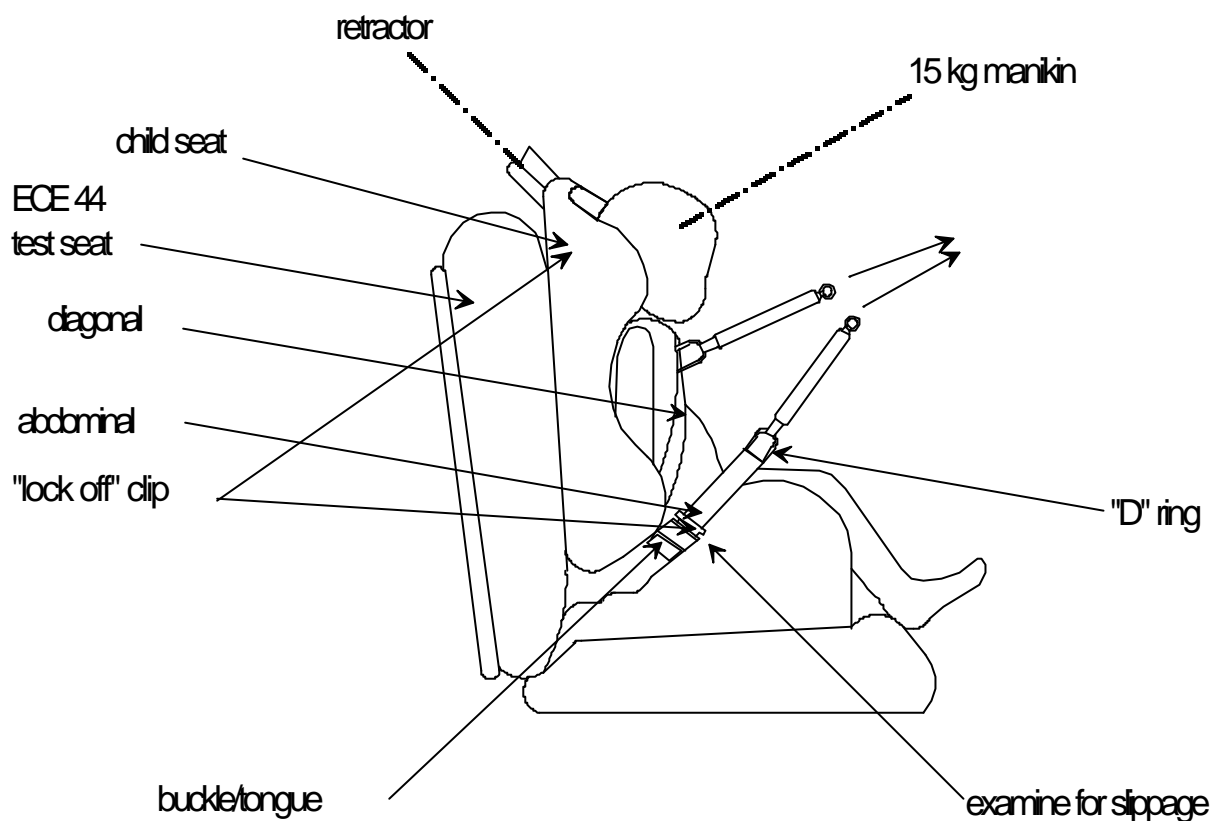
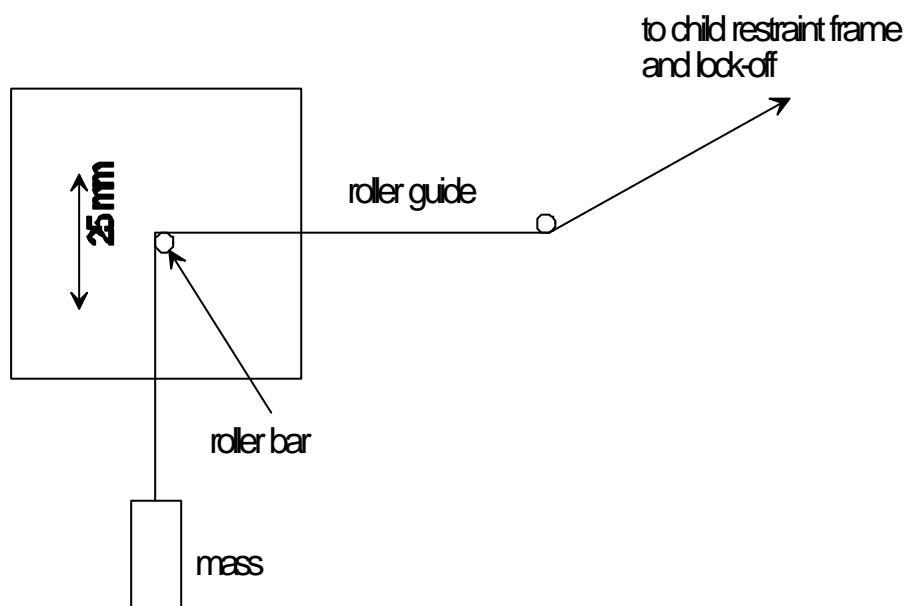

Figure 5

8.2.6.2. Class B Devices.

The child restraint shall be firmly secured and webbing, as specified in annex 13 to this Regulation, shall be passed through the lock-off and frame following the routing described in the manufacturer's instructions. The belt shall pass through the testing equipment as described in Figure 6 below and be attached to a mass of 5.25 ± 0.05 kg. There shall be

650 ± 40 mm of free webbing between the mass and the point where the webbing leaves the frame. The lock-off shall be fully applied and a mark made on the belt where it enters the lock-off. The mass shall be raised and released so that it falls freely over a distance of 25 ± 1 mm. This shall be repeated 100 times ± 2 at a frequency of 60 ± 2 cycles per minute, to simulate the jerking action of a child restraint in a car. A further mark shall be made on the belt where it enters the lock-off and the distance between the two marks shall be measured. The lock-off device must cover the full width of the webbing in the installed condition with 15 kg dummy installed. This test is to be conducted using the same webbing angles as those formed in normal use. The free end of the lap belt portion shall be fixed. The test shall be conducted with the child restraint system firmly attached to the test bench used in the overturning or dynamic test. The loading strap can be attached to the simulated buckle.



Drop height of mass = 25 mm
Distance from roller bar to roller guide = 300 mm

Using strap of the webbing specified for the standard seat belt as defined in Annex 13.

Figure 6:
Schematic layout of Class B Lock-off test.

8.2.7. Conditioning test for adjusters mounted directly on a child restraint

Install the largest dummy for which the restraint is intended, as if for the dynamic test, including the standard slack as specified in paragraph 8.1.3.6. Mark a reference line on the webbing where the free end of the webbing enters the adjuster.

Remove the dummy and place the restraint in the conditioning rig shown in Figure 1, annex 19.

The webbing must be cycled for a total distance of not less than 150 mm through the adjuster. This movement shall be such that at least 100 mm of webbing on the side of the reference line towards the free end of the webbing and the remainder of the moving distance (approx. 50 mm) on the integral harness side of the reference line moves through the adjuster.

If the length of webbing from the reference line to the free end of the webbing is insufficient for the movement described above, the 150 mm of movement through the adjuster shall be from the fully extended harness position.

The frequency of cycling shall be 10 ± 1 cycles/minute, with a velocity on "B" of 150 ± 10 mm/sec.

8.3. Certification of Test Bench Cushion

8.3.1. The test seat cushion shall be certified when new to establish initial values for impact penetration and peak deceleration, and then after every 50 dynamic tests or at least every month, whichever is the sooner, or before each test if the test rig is used frequently.

8.3.2. The certification and measuring procedures shall correspond to those specified in the latest version of ISO 6487; the measuring equipment shall correspond to the specification of a data channel with a channel filter class (CFC) 60.

Using the test device defined in annex 17 to this Regulation, conduct 3 tests, 150 ± 5 mm from the front edge of the cushion on the centre line and at 150 ± 5 mm in each direction from the centre line.

Place the device vertically on a flat rigid surface. Lower the impact mass until it contacts the surface and set the penetration marker to the zero position. Place the device vertically above the test point, raise the mass 500 ± 5 mm and allow it to fall freely to make impact on the seat surface. Record the penetration and the deceleration curve.

8.3.3. The peak values recorded shall not deviate by more than 15 per cent from the initial values.

8.4. High-speed films and videos

8.4.1. In order to determine the behaviour of the manikin and its displacements, all dynamic tests shall be filmed with cine film or video at a frequency of at least 400 frames/second.

8.4.2. Suitable calibration markings shall be mounted firmly on the trolley or in the vehicle structure so that the displacement of the manikin can be determined.

8.5. Electrical measurements.

The measuring procedures shall correspond to those defined in the latest edition of ISO 6487. The channel frequency classes shall be:

<u>Type of measurement</u>	<u>CFC (Hz)</u>
Belt loads	60
Head(form) acceleration	1000
Chest Acceleration.	180
Trolley Acceleration	60

The sample rate should be a minimum of eight times the F_H . (i.e, in installations with class 1000 pre-sample filters, this corresponds to a minimum sampling rate of approx. 8000 samples per second per channel).

9. TEST REPORT

9.1. The test report shall record the results of all tests and measurements and the trolley speeds, the place occupied by the buckle during the test, if it can be varied, and any failure or breakage.

9.2. If provisions relating to anchorages contained in annex 6, appendix 3, to this Regulation have not been respected, the test report shall describe how the child restraint is installed and shall specify important angles and dimensions.

9.3. When the child restraint is tested in a vehicle or vehicle structure, the test report shall specify the manner of attaching the vehicle structure to the trolley, the position of the child restraint and vehicle seat and the inclination of the vehicle seat-back.

10. MODIFICATIONS AND EXTENSION OF APPROVAL OF A TYPE OF CHILD RESTRAINT SYSTEM

10.1. Every modification of a child restraint shall be notified to the administrative department which approved the child restraint. The department may then either:

- 10.1.1. consider that the modifications made are unlikely to have an appreciable adverse effect and that in any case the child restraint still complies with the requirements; or
- 10.1.2. require a further test report from the technical service responsible for conducting the tests.
- 10.2. Confirmation or refusal of approval, specifying the alterations, shall be communicated by the procedure specified in paragraph 5.3. above to the Parties to the Agreement applying this Regulation.
- 10.3. The competent authority issuing the extension of approval shall assign a series number for such an extension and inform thereof the other Parties to the 1958 Agreement applying this Regulation by means of a communication form conforming to the model in annex 1 to this Regulation.
11. CONFORMITY OF PRODUCTION
 - 11.1. Any child restraint system approved to this Regulation shall be so manufactured as to conform to the type approved by meeting the requirements set forth in paragraphs 6 to 8 above.
 - 11.2. In order to verify that the requirements of paragraph 11.1. are met, suitable controls of the production shall be carried out.
 - 11.3. The holder of the approval shall in particular:
 - 11.3.1. Ensure existence of procedures for the effective control of the quality of the child restraint systems;
 - 11.3.2. Have access to the control equipment necessary for checking the conformity of each approved type;
 - 11.3.3. Ensure that data of test results are recorded and that annexed documents remain available for a period to be determined in accordance with the administrative service;
 - 11.3.4. Analyze the results of each type of test, in order to verify and ensure the stability of the child restraint system characteristics, making allowance for variation of an industrial production;
 - 11.3.5. Ensure that, for each type of child restraint system, at least the tests prescribed in annex 16 to this Regulation are carried out;
 - 11.3.6. Ensure that any samples or test pieces giving evidence of non-conformity with the type of test considered shall give rise to another sampling and another test. All the necessary steps shall be taken to re-establish the conformity of the corresponding production.

- 11.4. The competent authority which has granted type-approval may at any time verify the conformity control methods applicable to each production unit.
- 11.4.1. In every inspection, the test books and production survey records shall be presented to the visiting inspector.
- 11.4.2. The inspector may take samples at random which will be tested in the manufacturer's laboratory. The minimum number of samples may be determined according to the results of the manufacturer's own verification.
- 11.4.3. When the quality level appears unsatisfactory, or when it seems necessary to verify the validity of the tests carried out in application of paragraph 11.4.2 the inspector shall select samples to be sent to the technical service which has conducted the type-approval tests.
- 11.4.4. The competent authority may carry out any test prescribed in this Regulation.
- 11.4.5. The normal frequency of inspections authorized by the competent authority shall be two per year. In the case where negative results are recorded during one of these inspections, the competent authority shall ensure that all necessary steps are taken to re-establish the conformity of production as rapidly as possible.
12. PENALTIES FOR NON-CONFORMITY OF PRODUCTION
- 12.1. The approval granted in respect of a child restraint pursuant to this Regulation may be withdrawn if a child restraint bearing the particulars referred to in paragraph 5.4. fails to pass the random checks described in paragraph 11 or does not conform to the type approved.
- 12.2. If a Party to the Agreement which applies this Regulation withdraws an approval it has previously granted, it shall forthwith so notify the other Contracting Parties applying this Regulation by means of a communication form conforming to the model in annex 1 to this Regulation.
13. PRODUCTION DEFINITELY DISCONTINUED
- 13.1. If the holder of the approval completely ceases to manufacture a specific type of child restraint under this Regulation, he shall inform thereof the authority which granted the approval. Upon receiving the relevant communication, that authority shall inform the other Parties to the Agreement which apply this Regulation by means of a communication form conforming to the model in annex 1 to this Regulation.

14. INSTRUCTIONS

14.1. Each child restraint shall be accompanied by instructions in the language of the country where the device is sold with the following content:

14.2. Instructions on installation shall include the following points:

14.2.1. For "universal" category child restraints the following label shall be clearly visible at the point of sale without removing the packing:

Notice

1. This is a "Universal" child restraint. It is approved to Regulation No. 44, 03 series of amendments, for general use in vehicles and it will fit most, but not all, car seats.
2. A correct fit is likely if the vehicle manufacturer has declared in the vehicle handbook that the vehicle is capable of accepting a "Universal" child restraint for this age group.
3. This child restraint has been classified as "Universal" under more stringent conditions than those which applied to earlier designs which do not carry this notice.
4. If in doubt, consult either the child restraint manufacturer or the retailer.

14.2.2. For "restricted" and "semi-universal" category child restraints the following information shall be clearly visible at the point of sale without removing the packing:

This Child Restraint is classified for "(Restricted/Semi-universal)" use and is suitable for fixing into the seat positions of the following cars:

CAR	FRONT	REAR	
(Model)	Yes	Outer	Centre
	Yes	Yes	No

Seat positions in other cars may also be suitable to accept this child restraint. If in doubt, consult either the child restraint manufacturer or the retailer.

14.2.3. For "Specific vehicle" category child restraints information on the applicable vehicle shall be clearly visible at the point of sale without removing the packing.

- 14.2.4. If the device requires an adult safety-belt, the following wording should also be clearly visible at the point of sale without removing the packing:
- "Only suitable if the approved vehicles are fitted with lap/3 point/static/with retractor safety-belts, approved to UN/ECE Regulation No. 16 or other equivalent standards." (Strike out what does not apply.)
- In the case of carry-cot restraints a list of carry-cots for which the device is suited should be included.
- 14.2.5. The child restraint manufacturer shall provide information on the packing box as to the address to which the customer can write to obtain further information on fitting the child restraint in specific cars.
- 14.2.6. the method of installation illustrated by photographs and/or very clear drawings;
- 14.2.7. the user shall be advised that the rigid items and plastic parts of a child restraint must be so located and installed that they are not liable, during everyday use of the vehicle, to become trapped by a movable seat or in a door of the vehicle;
- 14.2.8. the user should be advised to use carry-cots perpendicular to the longitudinal axis of the vehicle;
- 14.2.9. in the case of rearward facing systems the customer shall be advised not to use them in seating positions where there is an airbag installed. This information shall be clearly visible at the point of sale without removing the packaging;
- 14.2.10. for "Special Needs Restraints" the following information shall be clearly visible at the point of sale without removing the packing:

This "Special Needs Restraint" is designed to give extra support to children who have difficulty in sitting correctly in conventional seats. Always consult your doctor to make sure that this restraint system is suitable for your child.

- 14.3. The instructions for use shall include the following points:
- 14.3.1. the weight groups for which the device is intended:
- 14.3.2. when the device is used in combination with an adult safety-belt to be used by means of the following wording: Only suitable for use in the listed vehicles fitted with lap/3 point/static/with retractor safety-belts, approved to ECE Regulation No. 16 or other equivalent standards. (Strike out what does not apply.)

- 14.3.3. the method of use shall be shown by photographs and/or very clear drawings. In the case of seats that can be used both forward and rear-facing, clear warning must be given to keep the restraint rear-facing until the child's mass is greater than a stated limit, or some other dimensional criterion is exceeded.
- 14.3.4. the operation of the buckle and adjusting devices shall be explained clearly;
- 14.3.5. it shall be recommended that any straps holding the restraint to the vehicle should be tight, that any straps restraining the child should be adjusted to the child's body, and that straps should not be twisted;
- 14.3.6. the importance of ensuring that any lap strap is worn low down, so that the pelvis is firmly engaged, shall be stressed;
- 14.3.7. it shall be recommended that the device should be changed when it has been subject to violent stresses in an accident;
- 14.3.8. instructions for cleaning shall be given;
- 14.3.9. a general warning shall be given to the user concerning the danger of making any alterations or additions to the device without the approval of the competent authority, and a danger of not following closely the installation instructions provided by the child restraint manufacturer;
- 14.3.10. when the chair is not provided with a textile cover, it shall be recommended that the chair should be kept away from sunlight, otherwise it may be too hot for the child's skin;
- 14.3.11. it shall be recommended that children are not left in their child restraint system unattended;
- 14.3.12. it shall be recommended that any luggage or other objects liable to cause injuries in the event of a collision shall be properly secured.
- 14.3.13. It shall be recommended that:
- (a) The child restraint must not be used without the cover.
 - (b) The seat cover should not be replaced with any other than the one recommended by the manufacturer, because the cover constitutes an integral part of the restraint performance.
15. NAMES AND ADDRESS OF TECHNICAL SERVICES RESPONSIBLE FOR CONDUCTING APPROVAL TESTS, AND OF ADMINISTRATIVE DEPARTMENTS
- 15.1. The Parties to the Agreement which apply this Regulation shall communicate to the United Nations secretariat the names and addresses of the technical services responsible for conducting

approval tests and of the administrative departments which grant approval and to which forms certifying approval or extension or refusal or withdrawal of approval, issued in other countries, are to be sent.

16. TRANSITIONAL PROVISIONS

- 16.1. As from the official date of entry into force of the 03 series of amendments, no Contracting Party applying this Regulation shall refuse to grant ECE approval under this Regulation as amended by the 03 series of amendments.
- 16.2. As from 12 months after the date of entry into force, Contracting Parties applying this Regulation shall grant ECE approvals only if the child restraint system type to be approved meets the requirements of this Regulation as amended by the 03 series of amendments.
- 16.3. During the 12-month period which follows the date of entry into force of the 03 series of amendments, Contracting Parties applying this Regulation can continue to grant type approvals to those child restraint systems which comply with the requirements of this Regulation as amended by the 02 series of amendments, provided that the requirements contained in paragraphs 6.1.7., 6.2.2., 6.2.14. 7.1.4.1.2., 7.1.4.1.5., 7.1.4.4.2., 7.2.4.4., 8.1.3.6.3.2., 8.4.1., 8.4.2., 14.3.12. and annex 16 of the 03 series of amendments to this Regulation are met.
- 16.4. In the same period of 12 months and under the same conditions provided for in the above paragraph, Contracting Parties applying this Regulations shall not refuse to grant extensions of approval to the preceding series of amendments to this Regulation.
- 16.5. As from the date of entry into force of the 03 series of amendments, the provisions of annex 16 to this Regulation shall apply also to child restraint devices already type approved to the 02 series of amendments.
- 16.6. Starting from the date of entry into force of the 03 series of amendments, Contracting Parties applying this Regulation may refuse the sale of a type of child restraint which does not meet the requirements of paragraphs 6.2.2. and 6.2.14. of the 03 series of amendments.
- 16.7. Starting 36 months after the entry into force of the 03 series of amendments, Contracting Parties applying this Regulation may refuse the sale of child restraint systems which do not meet the requirements of the 03 series of amendments to this Regulation.
-

8. Technical service conducting approval tests
9. Date of test report issued by that service
10. Number of test report issued by that service
11. Approval granted/extended/refused/withdrawn 2/ for use in Groups 0, 0+, I, II or III and for universal/semi-universal/restricted use or use in a specific vehicle or for use as a "special needs restraint", position in vehicle
12. Position and nature of the marking
13. Place
14. Date
15. Signature
16. The following documents, bearing the approval number shown above, are attached to this communication:
 - drawings, diagrams and plans of the child restraint, including any retractor, chair assembly, impact shield fitted;
 - drawings, diagrams and plans of the vehicle structure and the seat structure, as well as of the adjustment system and the attachments, including any energy absorber fitted;
 - photographs of the child restraint and/or vehicle structure and seat structure;
 - instructions for fitting and use;
 - list of vehicle models for which the restraint is intended.

1/ Distinguishing number of the country which has granted/extended/refused/withdrawn approval (see approval provisions in the Regulation).

2/ Strike out what does not apply.

Annex 2

ARRANGEMENTS OF THE APPROVAL MARK

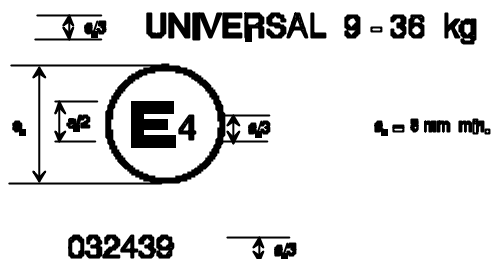

The child restraint system bearing the above approval mark is a device capable of being fitted in any vehicle and of being used for the 9 kg-36 kg mass range (Groups I to III); it is approved in the Netherlands (E4) under the number 032439. The approval number indicates that the approval was granted in accordance with the requirements of the Regulation concerning the approval of restraining devices for child occupants of power-driven vehicles ('child restraint system') as amended by the 03 series of amendments.

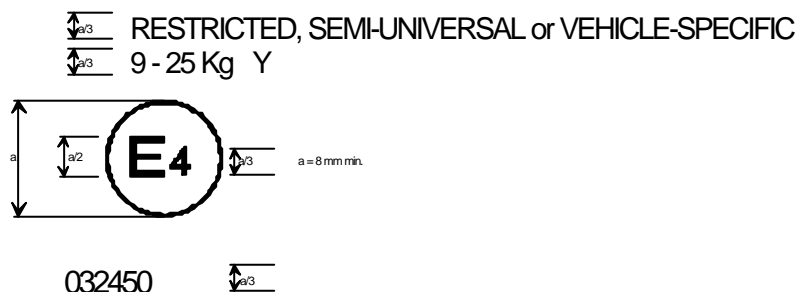

The child restraint system bearing the above approval mark is a device not capable of being fitted in every vehicle and of being used for the 9 kg-25 kg mass range (Groups I and II); it is approved in the Netherlands (E4) under the number 032450. The approval number indicates that the approval was granted in accordance with the requirements of the Regulation concerning the approval of restraining devices for child occupants of power-driven vehicles ('child restraint system') as amended by the 03 series of amendments. The symbol 'Y' indicates that the system contains a crotch strap.

E/ECE/324
E/ECE/TRANS/505, Rev.1/Add.43/Rev.1
Regulation No. 44
page 66
Annex 2

Note: The approval number and additional symbol(s) must be placed close to the circle and either above or below the 'E' or to left or right of it. The digits of the approval number must be on the same side of the 'E' and oriented in the same direction. The additional symbol(s) must be diametrically opposite the approval number. The use of Roman numerals as approval numbers should be avoided so as to prevent any confusion with other symbols.

Annex 3

ARRANGEMENT OF APPARATUS FOR DUST RESISTANCE TEST

(dimensions in millimetres)

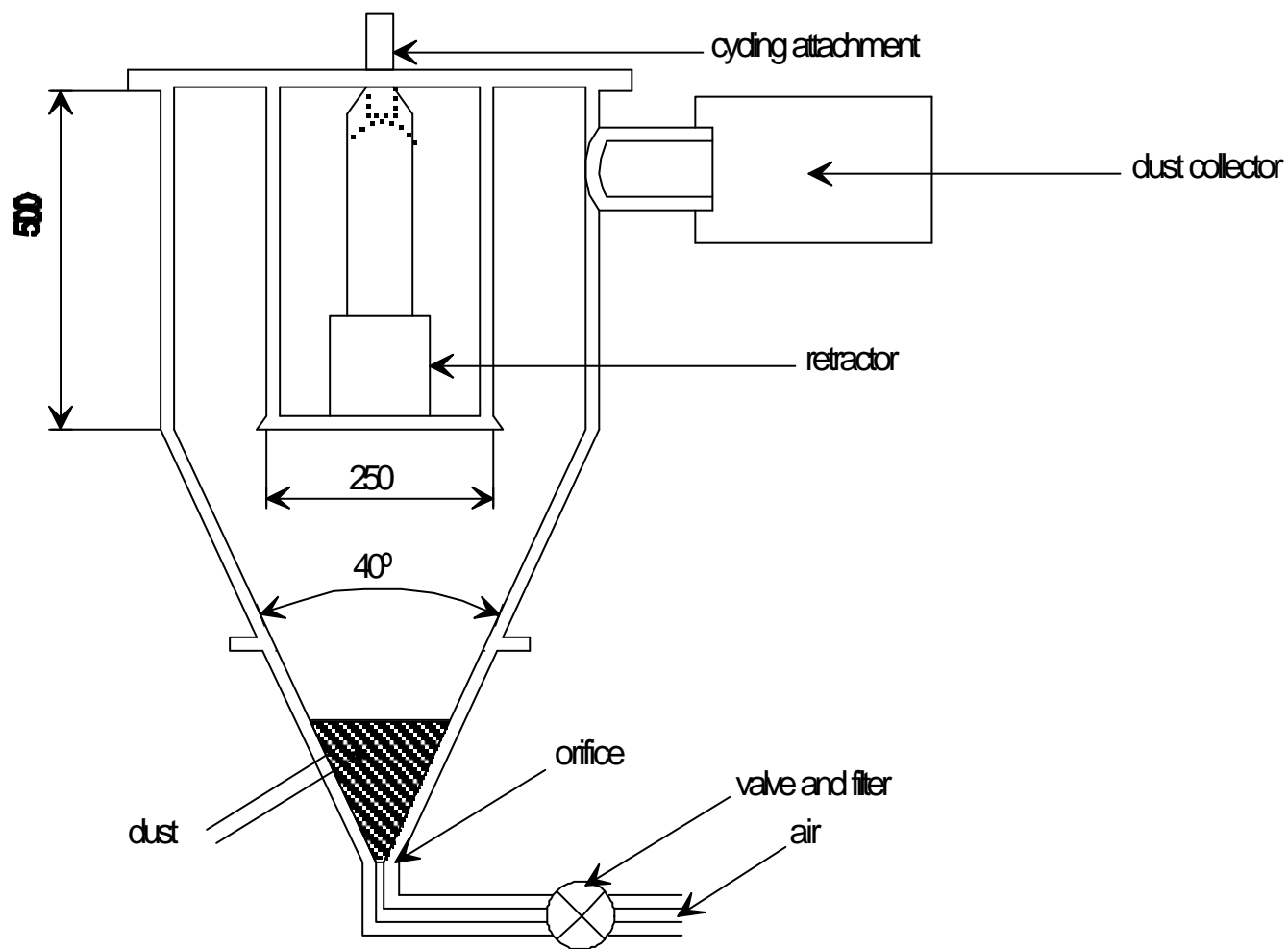
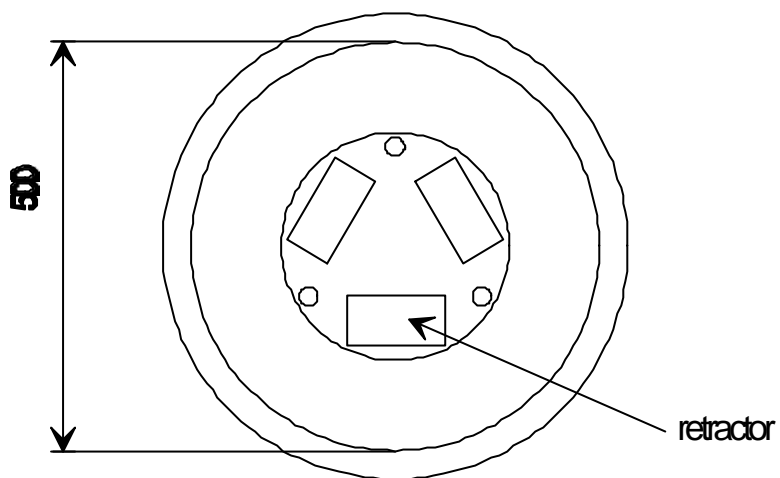

Annex 4

CORROSION TEST

1. Test apparatus

- 1.1. The apparatus shall consist of a mist chamber, a salt solution reservoir, a supply of suitably conditioned compressed air, one or more atomizing nozzles, sample supports, provision for heating the chamber, and necessary means of control. The size and detailed construction of the apparatus shall be optional, provided that the test conditions are met.
- 1.2. It is important to ensure that drops of solution accumulated on the ceiling or cover of the chamber do not fall on test samples.
- 1.3. Drops of solution which fall from test samples shall not be returned to the reservoir for respraying.
- 1.4. The apparatus shall not be constructed of materials that will affect the corrosiveness of the mist.

2. Location of test samples in the mist cabinet

- 2.1. Samples, except retractors, shall be supported or suspended between 15E and 30E from the vertical and preferably parallel to the principal direction of horizontal flow of mist through the chamber, based upon the dominant surface being tested.
- 2.2. Retractors shall be supported or suspended so that the axes of the reel for storing the strap shall be perpendicular to the principal direction of horizontal flow of mist through the chamber. The strap opening in the retractor shall also be facing in this principal direction.
- 2.3. Each sample shall be so placed as to permit free settling of mist on all samples.
- 2.4. Each sample shall be so placed as to prevent salt solution from one sample dripping on to any other sample.

3. Salt solution

- 3.1. The salt solution shall be prepared by dissolving 5 ± 1 parts by mass of sodium chloride in 95 parts of distilled water. The salt shall be sodium chloride substantially free of nickel and copper and containing not more than 0.1 per cent of sodium iodide and not more than 0.3 per cent of total impurities in the dry state.
- 3.2. The solution shall be such that, when atomized at 35°C, the collected solution is in the pH range of 6.5 to 7.2.

4. Compressed air

4.1. The compressed air supply to the nozzle or nozzles for atomizing the salt solution shall be free of oil and dirt, and maintained at a pressure between 70 kN/m² and 170 kN/m².

5. Conditions in the mist chamber

5.1. The exposure zone of the mist chamber shall be maintained at 35 ± 5EC. At least two clean mist collectors shall be placed within the exposure zone, so that no drops of solution from the test samples or any other sources are collected. The collectors shall be placed near the test samples, one as near as possible to any nozzle and one as far as possible from all nozzles. The mist shall be such that, for each 80 cm² of horizontal collecting area, from 1.0 to 2.0 ml of solution per hour, when measured over an average of at least 16 hours, is collected in each collector.

5.2. The nozzle or nozzles shall be directed or baffled, so that the spray does not impinge directly on the test samples.

Annex 5

ABRASION AND MICROSILIP TEST

Figure 1: PROCEDURE TYPE 1

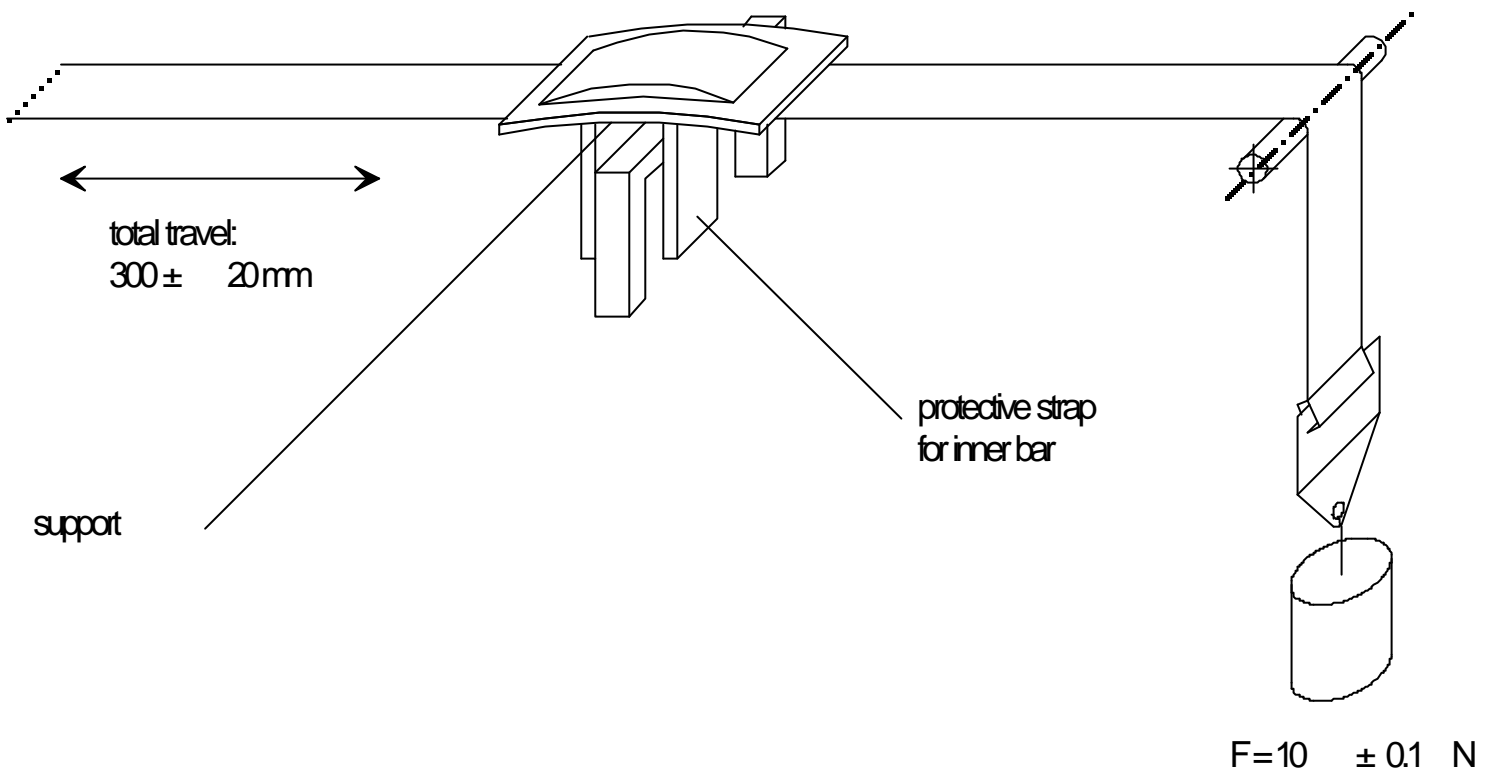

Example a

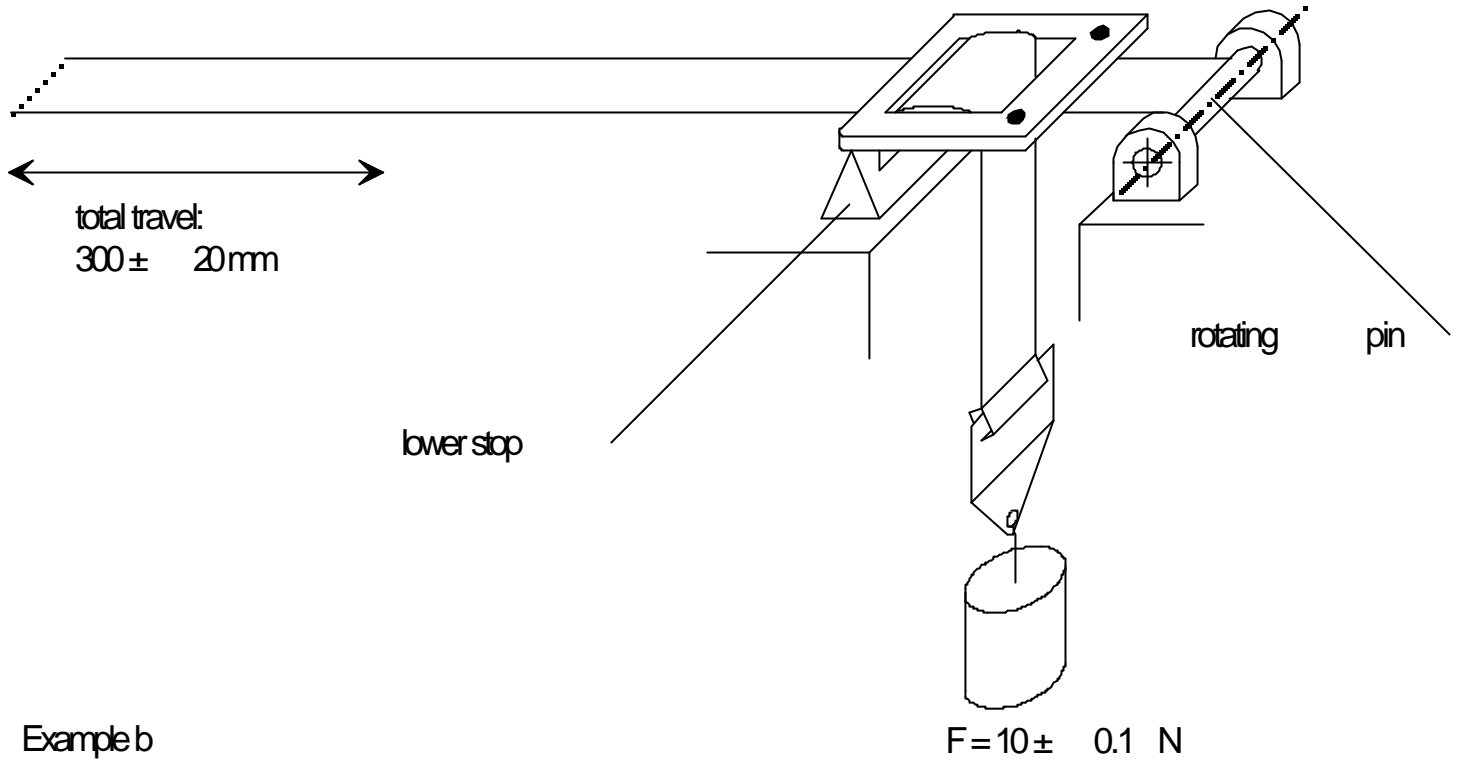

Example b
Examples of test arrangements corresponding
to the type of adjusting device

Figure 2
Procedure type 2

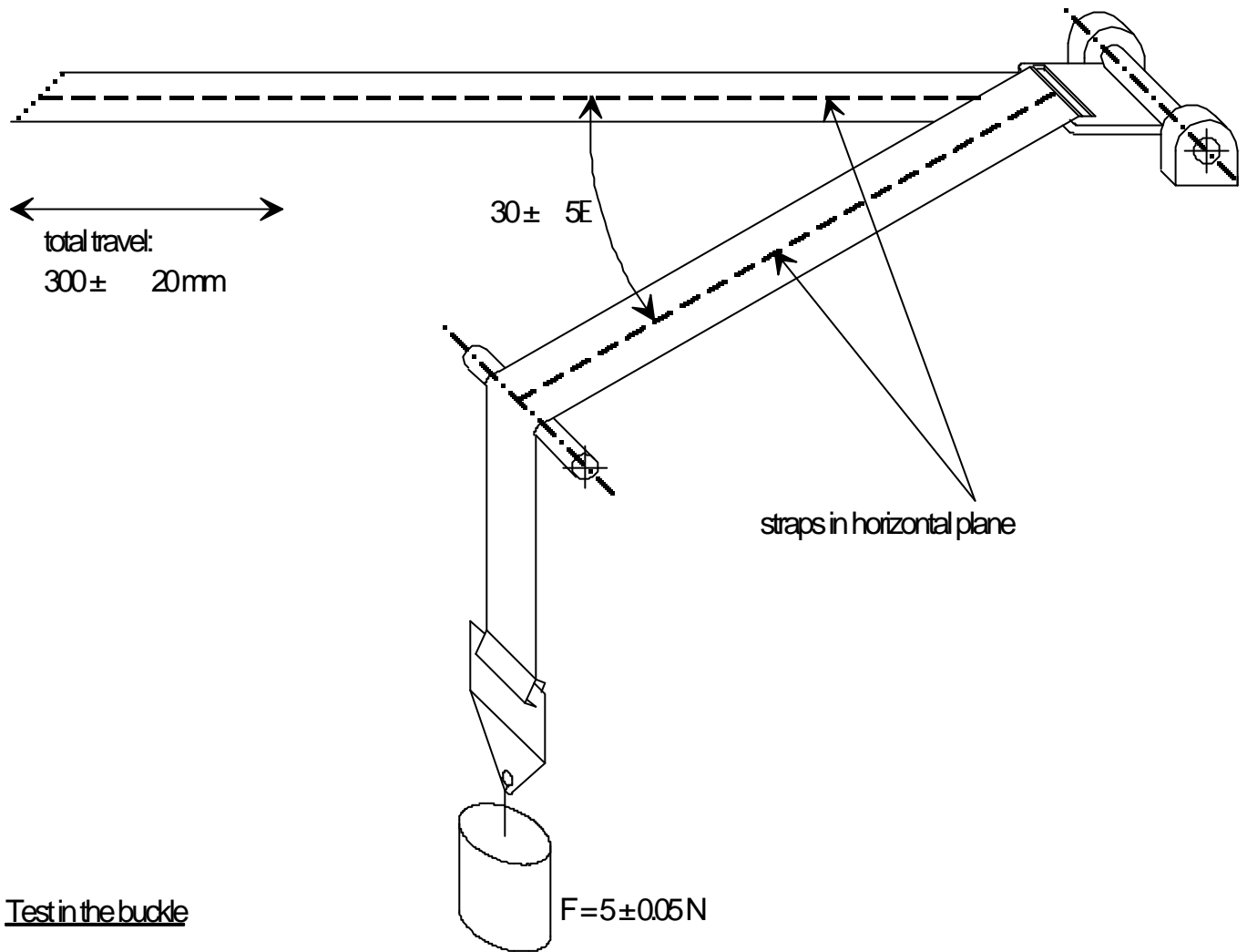

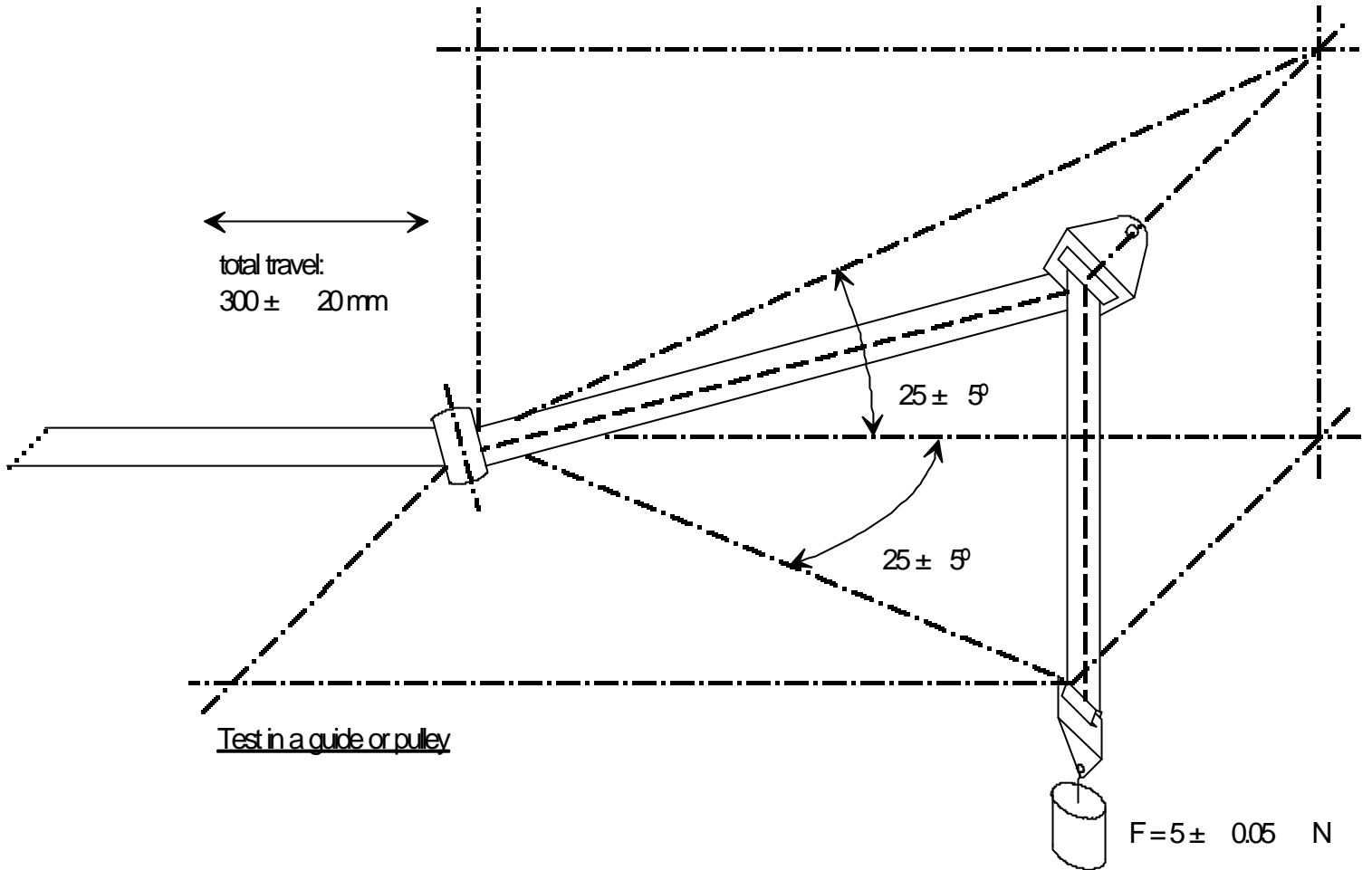
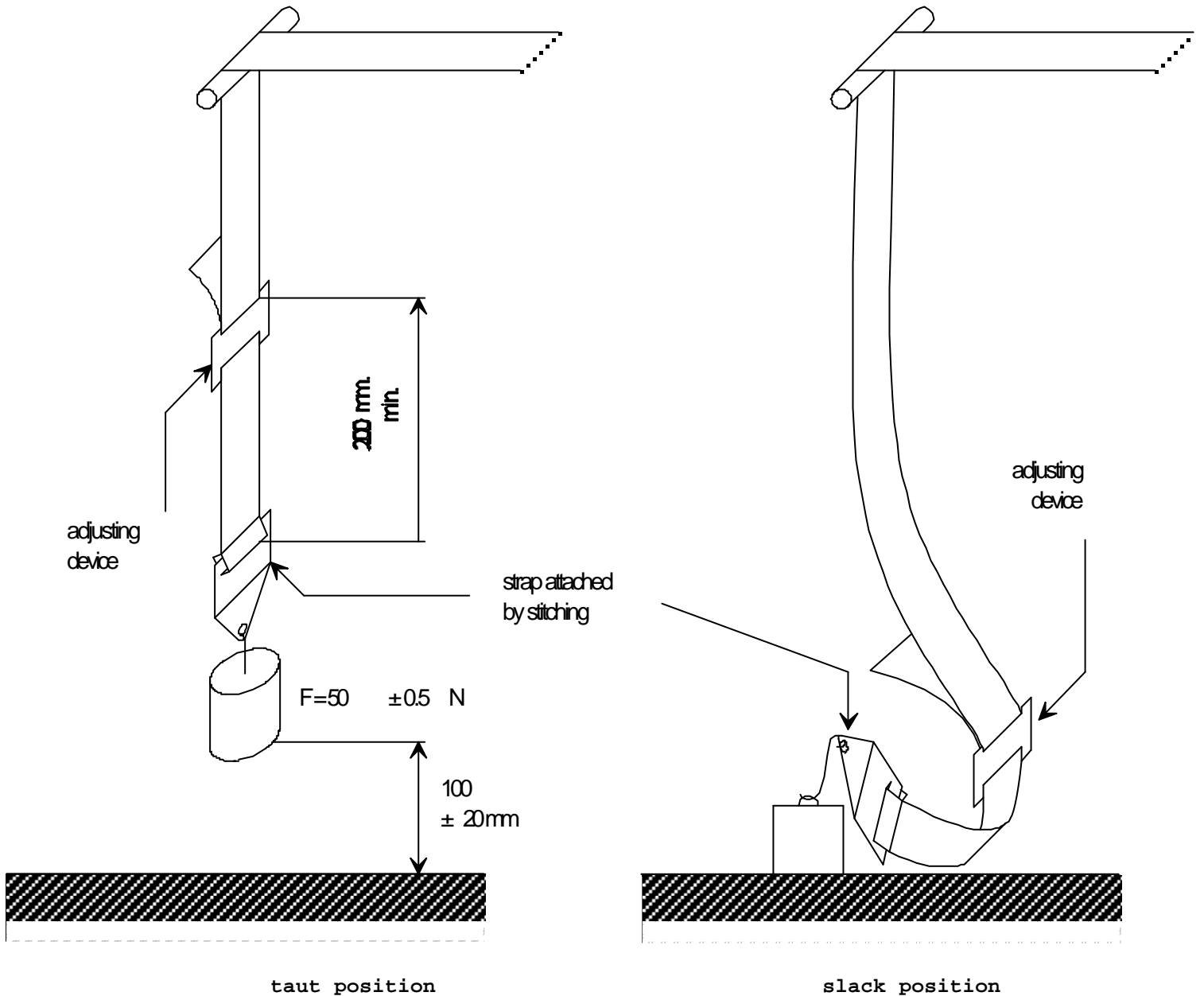

Figure 3: MICROSLIP TEST

Total travel: 300 ± 20 mm



The load of 50 N on the testing device shall be vertically guided in such a way as to prevent load-swing and twisting of the strap.

The attaching device shall be fixed to the load of 50 N in the same manner as in the vehicle.

E/ECE/324
E/ECE/TRANS/505^a Rev.1/Add.43/Rev.1
Regulation No. 44
page 76
Annex 5

Annex 6

DESCRIPTION OF TROLLEY

1. Trolley
 - 1.1. For tests on safety belts, the trolley, carrying the seat only, shall have a mass of 400 ± 20 kg. For tests on restraint systems, the trolley with the attached vehicle structure shall have a mass of 800 kg. However, the total mass of the trolley and vehicle structure may, if necessary, be increased by increments of 200 kg. In no case shall the total mass differ from the nominal value by more than ± 40 kg.
2. Calibration screen
 - 2.1. A calibration screen shall be attached firmly to the trolley with a movement limit line plainly marked on it to enable compliance with forward movement criteria to be determined from photographic records.
3. Seat
 - 3.1. The seat shall be constructed as follows:
 - 3.1.1. A rigid back, fixed, dimensions of which are given in appendix 1 to this annex. The lower part and the upper part is made of a 20 mm diameter tube;
 - 3.1.2. Rigid seating, dimensions of which are given in appendix 1 to this annex. The rear part of the seating is made from a rigid sheet metal, the upper edge of which is a 20 mm diameter tube. The front part of the seating is also made of a 20 mm diameter tube;
 - 3.1.3. For access to the anchor brackets, openings shall be made at the rear of the cushion of the seat, as prescribed in appendix 1 to this annex;
 - 3.1.4. The width of the seat shall be 800 mm;
 - 3.1.5. The back and the seating shall be covered with polyurethane foam, the characteristics of which are given in Table 1. The dimensions of the cushion are given in appendix 1 to this annex;

Table 1:

Density according to ISO 485 (kg/m ³)	43
Bearing strength according to ISO 2439B (N)	
p - 25%	125
p - 40%	155
Bearing strength factor according to ISO 3386 (kPa)	4
Elongation at rupture according to ISO 1798 (%)	180
Breaking strength according to ISO 1798 (kPa)	100
Compression set according to ISO 1856 (%)	3

- 3.1.6. The polyurethane foam shall be covered with a sun shade cloth, made of poly-acrylate fibre, the characteristics of which are given in Table 2.

Table 2:

Specific mass (g/m ²)	290
Breaking strength according to DIN 53587 on test specimen 50 mm wide:	
lengthwise (kg):	120
breadthwise (kg):	80

- 3.1.7. Covering the seat and the seat back 1/

- 3.1.7.1. The seat foam cushion is produced out of a square foam block (800 x 575 x 135 mm) in such a way (see Figure 1 of appendix 1 to this annex) that its shape resembles the shape of the aluminium bottom-plate specified in Figure 2 of appendix 1 to this annex.
- 3.1.7.2. Six holes are drilled in the bottom-plate in order to fasten it to the trolley with bolts. The holes are drilled alongside the longest side of the plate, three on each side, their position being dependent on the construction of the trolley. Six bolts are put through the holes. It is recommended to glue the bolts on the plate with an appropriate adhesive. Afterwards, the bolts are fastened with nuts.

1/ Details of materials used in this process can be obtained from TNO (Research Institute for Road Vehicles), Schoemakerstraat 97, 2628 VK Delft, The Netherlands.

- 3.1.7.3. The cover material (1250 x 1200 mm, see Figure 3 of appendix 1 to this annex) is cut across the width in such a way that it is not possible for the material to overlap after covering. There should be a gap of about 100 mm between the edges of the cover material. Therefore the material has to be cut at about 1200 mm.
- 3.1.7.4. The cover material is marked with two lines which run across the width. They are drawn 375 mm from the centreline of the cover material. (See Figure 3 of appendix 1 to this annex)
- 3.1.7.5. The seat foam cushion is placed upside down on the cover material with the aluminium bottom-plate on top.
- 3.1.7.6. On both sides the cover material is stretched until the lines drawn on it match the edges of the aluminium bottom-plate. At each bolt position, small incisions are made and the cover material is pulled over the bolts.
- 3.1.7.7. At the position of the grooves in the bottom-plate and in the foam, the cover material should be incised.
- 3.1.7.8. The cover is glued to the aluminium plate with a flexible glue. The nuts have to be removed before gluing.
- 3.1.7.9. The flaps on the side are folded onto the plate and are glued as well.
- 3.1.7.10. The flaps in the grooves are folded inside and taped with a strong tape.
- 3.1.7.11. The flexible glue has to dry for at least 12 hours.
- 3.1.7.12. The seat back cushion is covered in exactly the same way as the seat, only the lines on the cover material (1250 x 850 mm) are drawn 320 mm apart from the centreline of the material.
- 3.1.8. Line Cr is coincident with the intersection line between the top plane of the seat and the front lane of the seat back.
- 3.2. Test of rearward-facing devices
 - 3.2.1. A special frame shall be fitted on the trolley in order to support the child restraint as shown in figure 1.

3.2.2. A steel tube shall be attached firmly to the trolley in such a way that a load of $5,000 \pm 50$ N applied horizontally to the centre of the tube does not cause a movement greater than 2 mm.

3.2.3. The dimensions of the tube shall be: 500 x 100 x 90 mm.

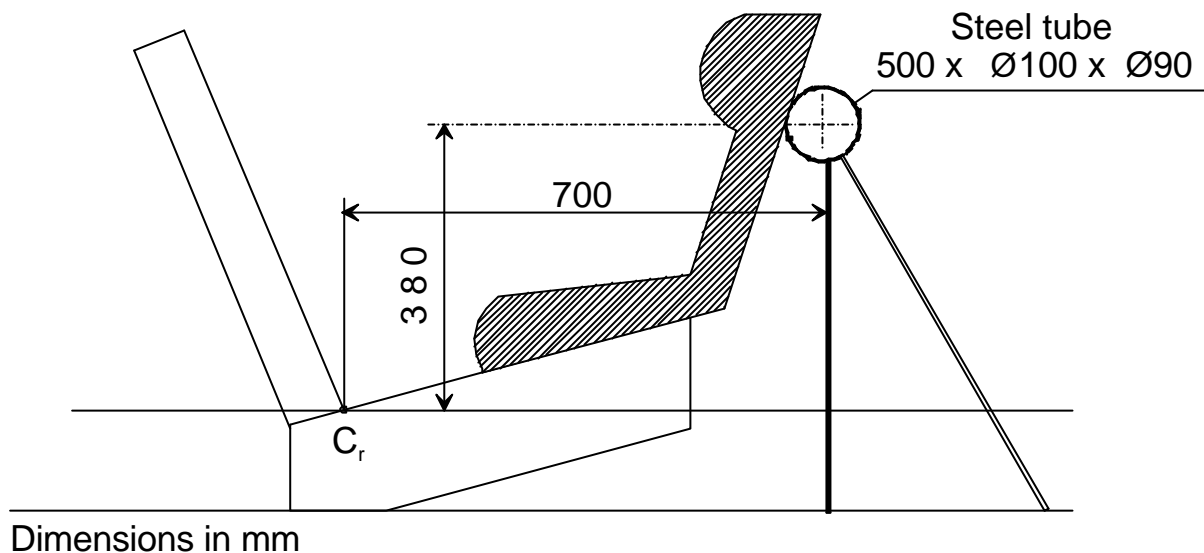

Figure 1

Arrangement for testing a rearward-facing device

4. Stopping device

4.1. The device consists of two identical absorbers mounted in parallel.

4.2. If necessary, an additional absorber shall be used for each 200 kg increase in nominal mass. Each absorber shall comprise:

4.2.1. an outer casing formed from a steel tube;

4.2.2. a polyurethane energy-absorber tube;

4.2.3. a polished-steel olive-shaped knob penetrating into the absorber;
and

4.2.4. a shaft and an impact plate.

- 4.3. The dimensions of the various parts of this absorber are shown in the diagram reproduced in appendice 2 to this annex.
- 4.4. The characteristics of the absorbing material are given in table 3 and table 4 of this annex.
- 4.5. The stopping device assembly shall be maintained for at least 12 hours at a temperature between 15E and 25EC before being used for the calibration tests described in annex 7 to this Regulation. The stopping device shall, for each type of test, meet the performance requirements laid down in annex 7, appendices 1 and 2. For dynamic tests of a child restraint, the stopping device assembly shall be maintained for at least 12 hours at the same temperature, to within $\pm 2\text{EC}$, as that of the calibration test. Any other device giving equivalent results can be accepted.

Table 3

CHARACTERISTICS OF THE ABSORBING MATERIAL "A" 1/
(ASTM Method D 735 unless otherwise stated)

Shore hardness A:	95 ± 2 at 20 ± 5°C temperature
Breaking strength:	R ₀ \$ 350 kg/cm ²
Minimum elongation:	A ₀ \$ 400%
Module at 100% elongation:	\$ 110 kg/cm ²
at 300% elongation:	\$ 240 kg/cm ²
Low temperature brittleness (ASTM Method D 736): 5 hours at - 55°C	
Compression set (Method B): 22 hours at 70°C # 45%	
Density at 25°C:	1.05 to 1.10
Ageing in air (ASTM Method D 573):	
70 hours at 100°C:	Shore hardness: max. variation ± 3
	breaking strength: decrease < 10% of R ₀
	elongation: decrease < 10% of A ₀
	weight: decrease < 1%
Immersion in oil (ASTM Method No. 1 Oil):	
70 hours at 100°C:	Shore hardness: max. variation ± 4
	breaking strength: decrease < 15% of R ₀
	elongation: decrease < 10% of A ₀
	volume: swelling < 5%
Immersion in oil (ASTM Method No. 3 Oil):	
70 hours at 100°C:	breaking strength: decrease < 15% of R ₀
	elongation: decrease < 15% of A ₀
	volume: swelling < 20%
Immersion in distilled water:	
	breaking strength: decrease < 35% of R ₀
1 week at 70°C:	
	elongation: increase < 20% of A ₀

1/ The address to obtain the relevant ASTM standards is: ASTM,
1916 Race Street, Philadelphia, USA PA 19 103.

Table 4

CHARACTERISTICS OF THE ABSORBING MATERIAL "B"

(ASTM Method 2000 (1980) unless otherwise stated)

Shore hardness A: 88 ± 2 at 20 ± 5EC temperature
Breaking strength: R_o \$ 300 kg/cm²
Minimum elongation: A_o \$ 400%
Module at 100% elongation: \$ 70 kg/cm²
at 300% elongation: \$ 130 kg/cm²

Low temperature brittleness (ASTM Method D 736): 5 hours at - 55EC
Compression set (Method B): 22 hours at 70EC # 45%
Density at 25EC: 1.08 to 1.12
Ageing in air (ASTM Method D 573 (1981)):

70 hours at 100EC: Shore hardness: max. variation ± 3
breaking strength: decrease < 10% of R_o
elongation: decrease < 10% of A_o
weight: decrease < 1%

Immersion in oil (ASTM Method D 471 (1979) Oil No. 1):

70 hours at 100EC: Shore hardness: max. variation ± 4
breaking strength: decrease < 15% of R_o
elongation: decrease < 10% of A_o
volume: swelling < 5%

Immersion in oil (ASTM Method D 471 (1979) Oil No. 3):

70 hours at 100EC: breaking strength: decrease < 15% of R_o
elongation: decrease < 15% of A_o
volume: swelling < 20%

Immersion in distilled water:

1 week at 70EC: breaking strength: decrease < 35% of R_o
elongation: increase < 20% of A_o

Annex 6 - Appendix 1

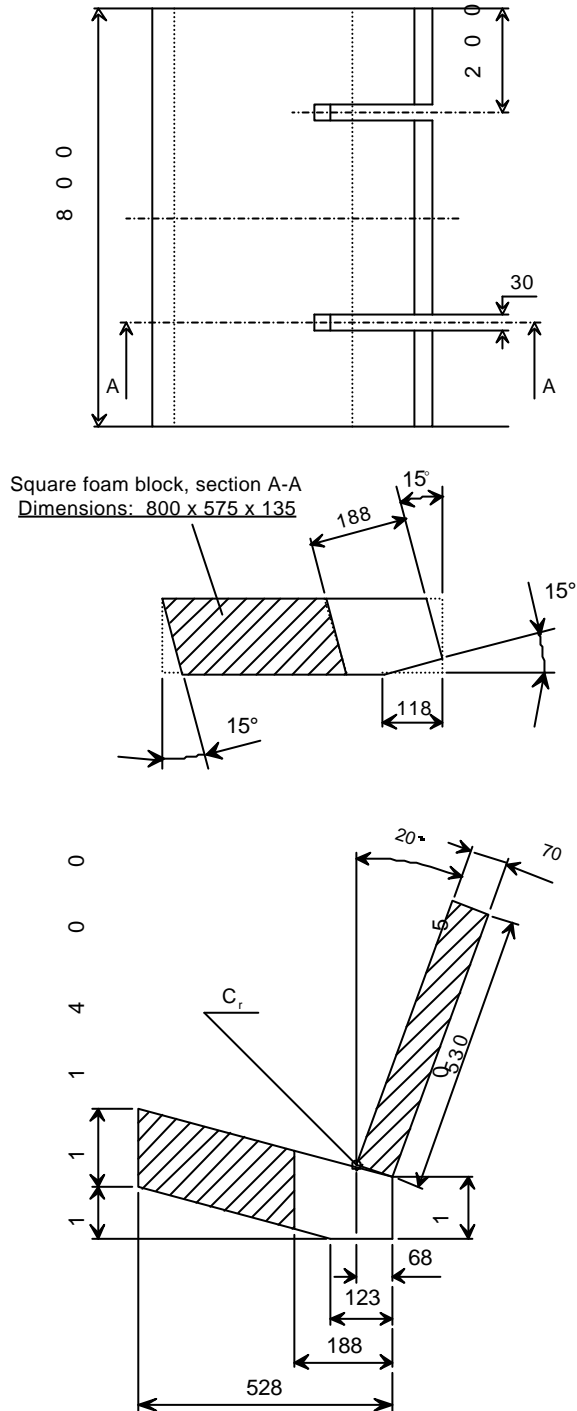

Figure 1

Dimensions of the seat and the seat cushions

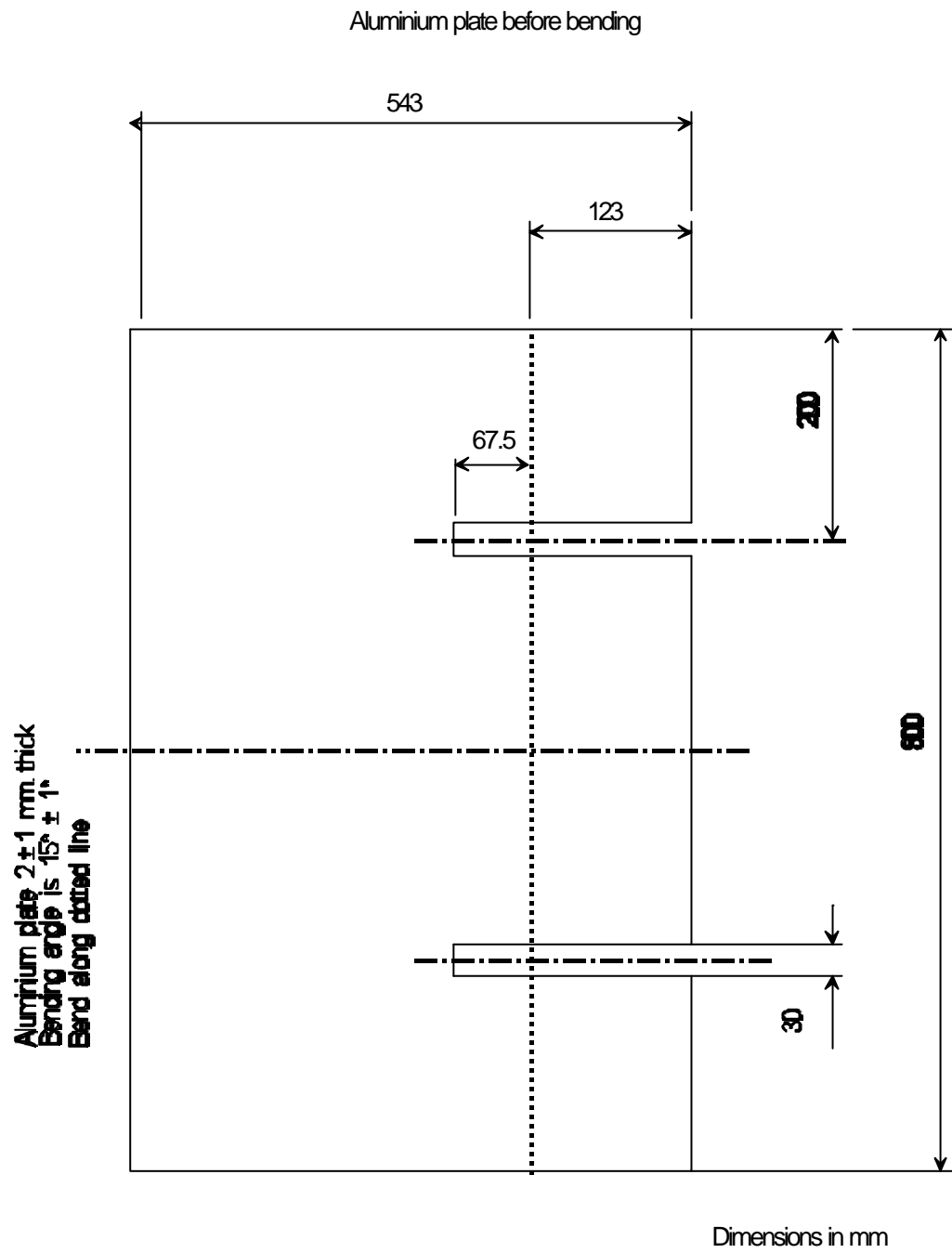

Figure 2: Dimensions of the aluminium bottom-plate

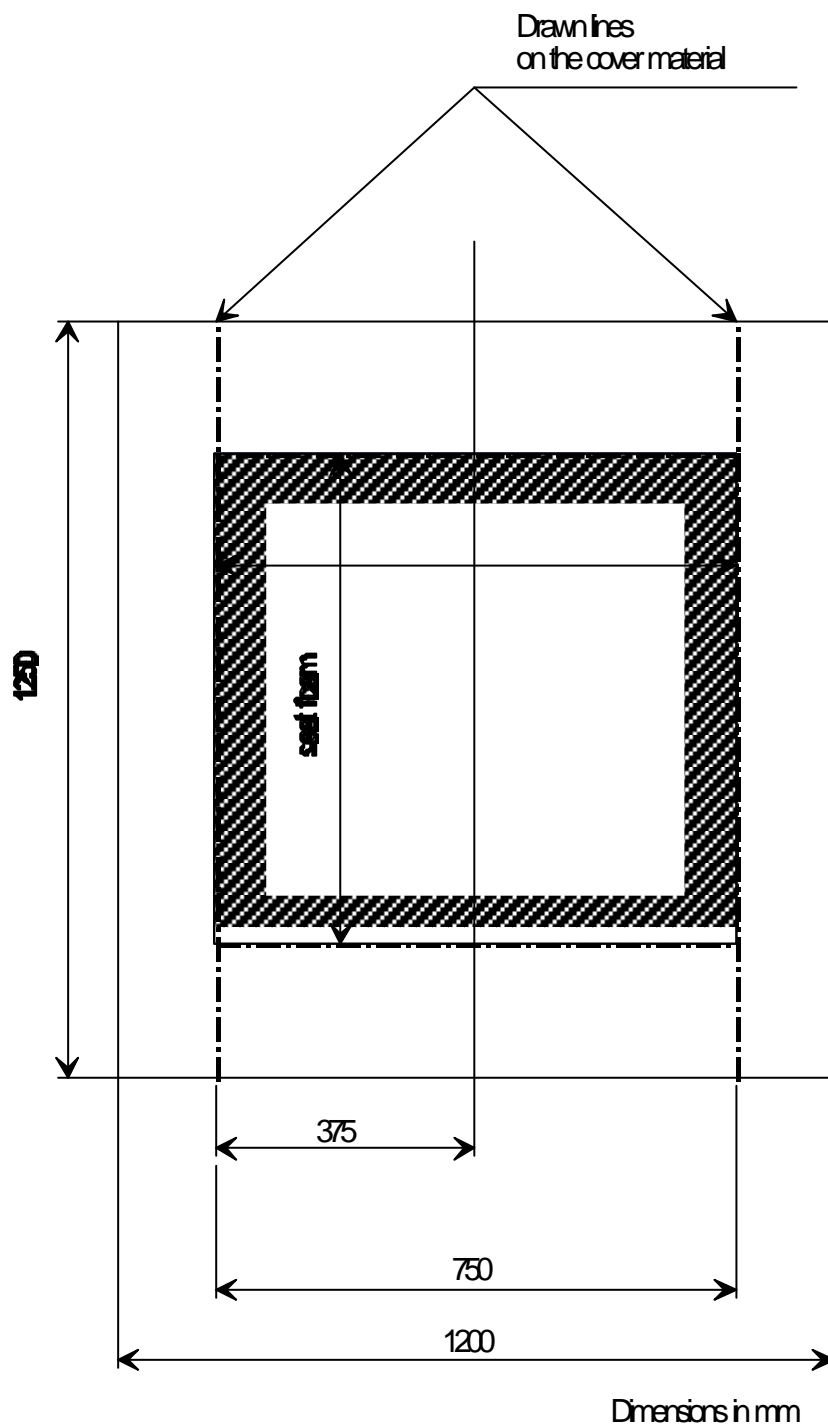

Figure 3: Dimensions of the cover material

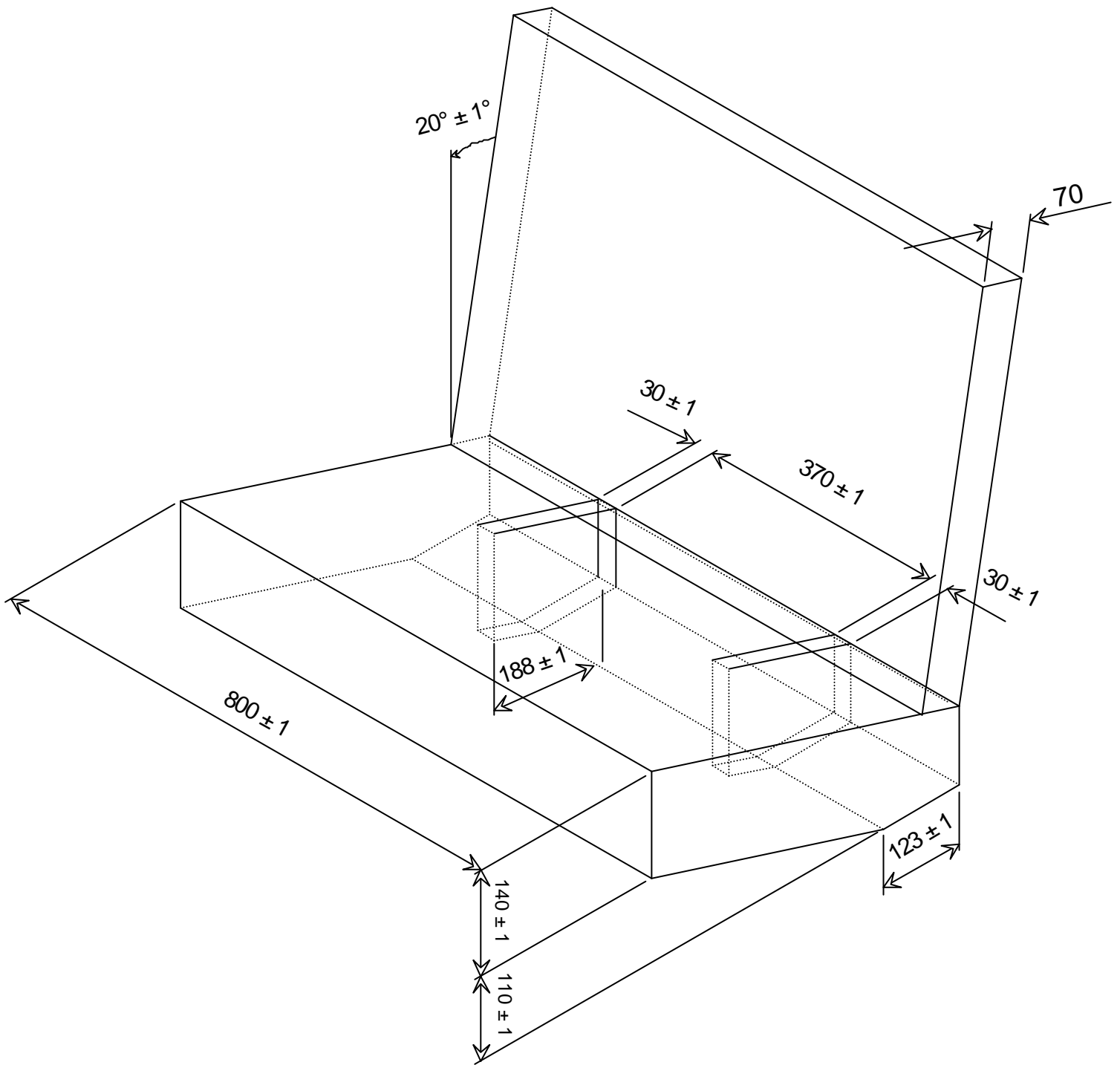

Figure 4:
3- Dimensional view of seat

2

3 4

5

Annex 6 - Appendix 2
 Stopping device
 Frontal Impact dimensions (in mm)

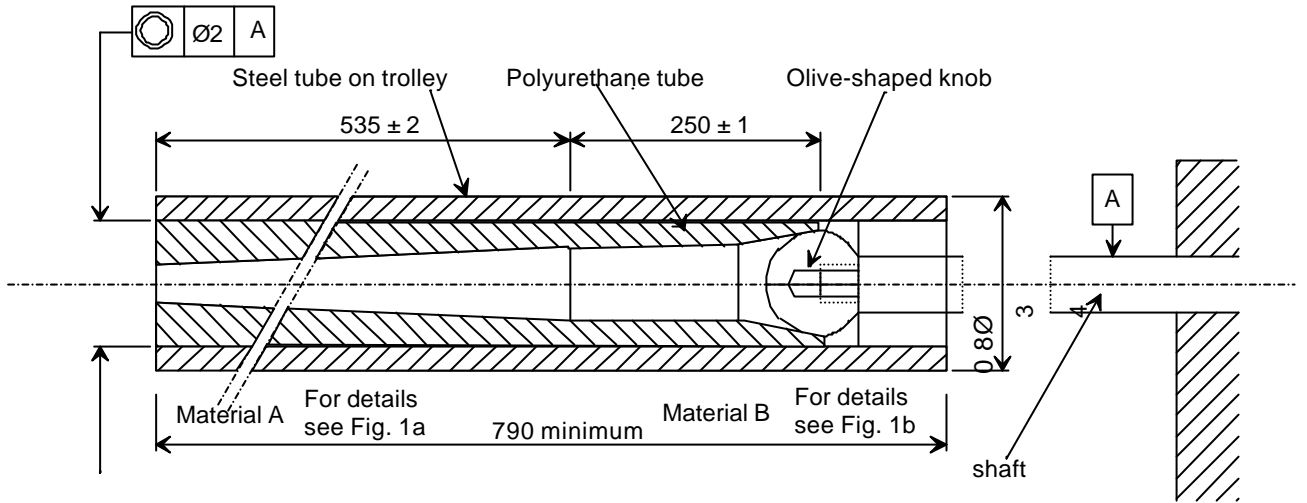

Play defined according to external diameter of polyurethane tube (light push fit)

3.2  surface finish

Figure 1

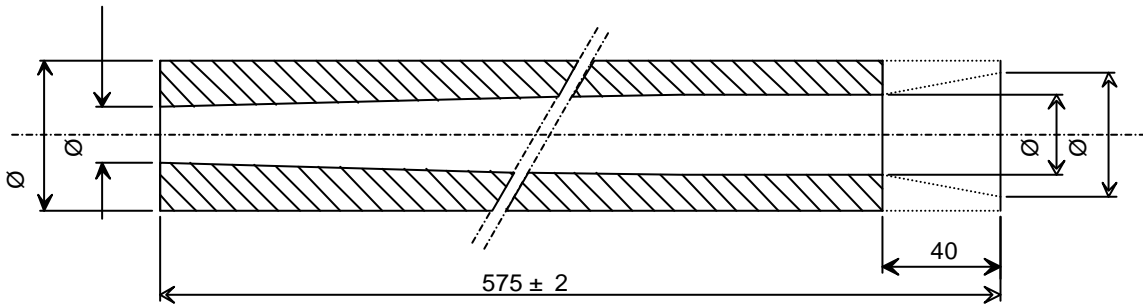

Figure 1a: Material A

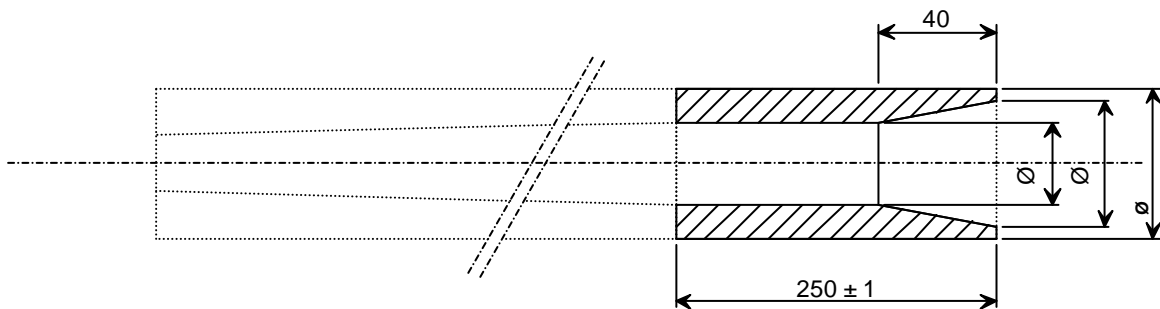
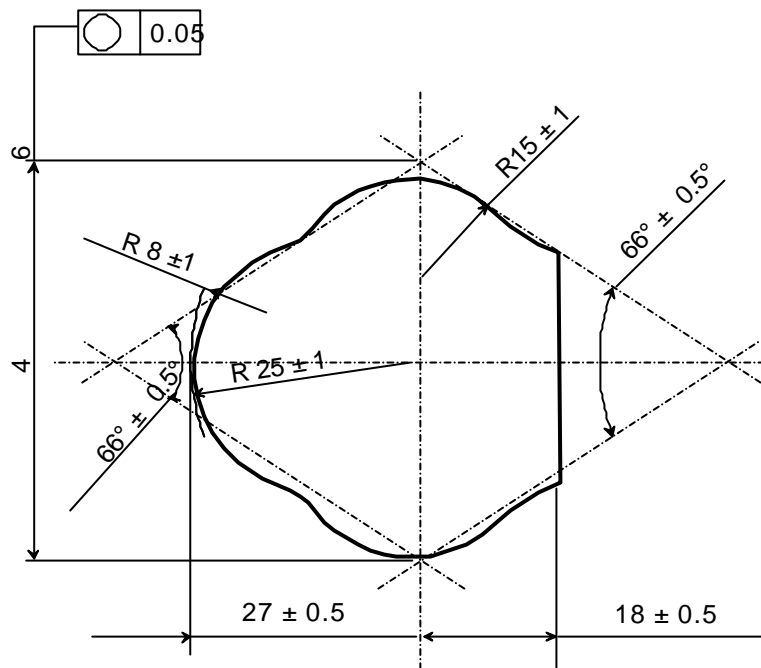

Figure 1b: Material B

5

9



* This dimension can vary between 43 and 49 mm

Dimensions in mm

Figure 2:
 Stopping device olive-shaped knob

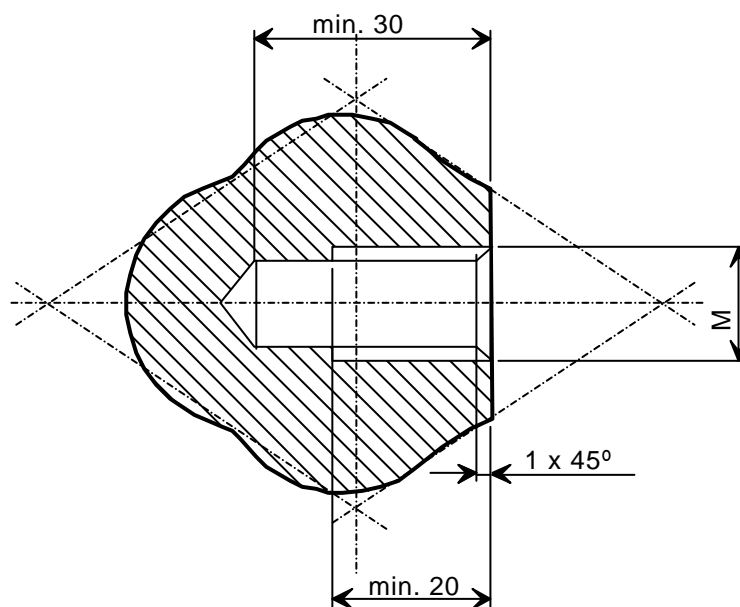

Dimensions in mm

Figure 3:
 Stopping device olive-shaped knob

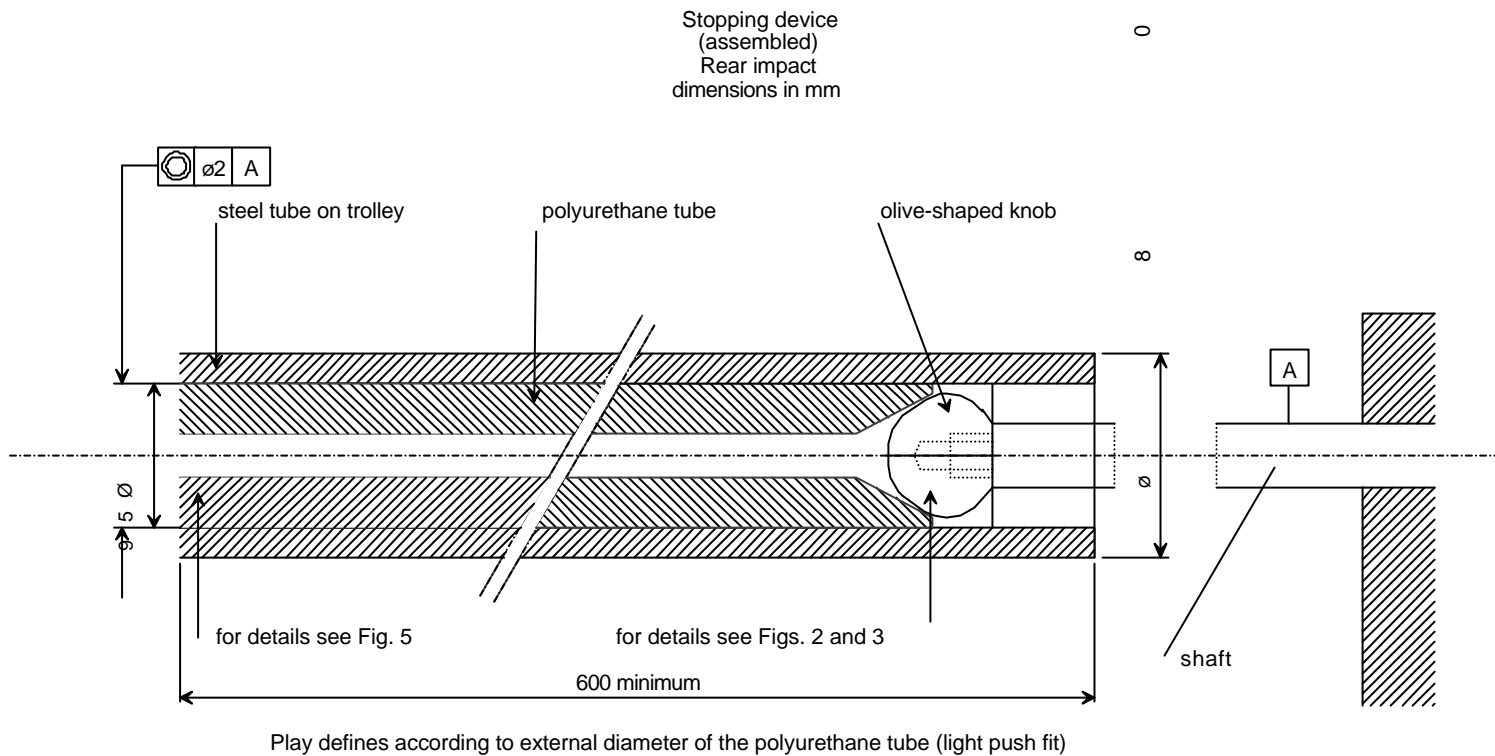

Figure 4

Stopping device
polyurethane tube
Rear impact
dimensions in mm

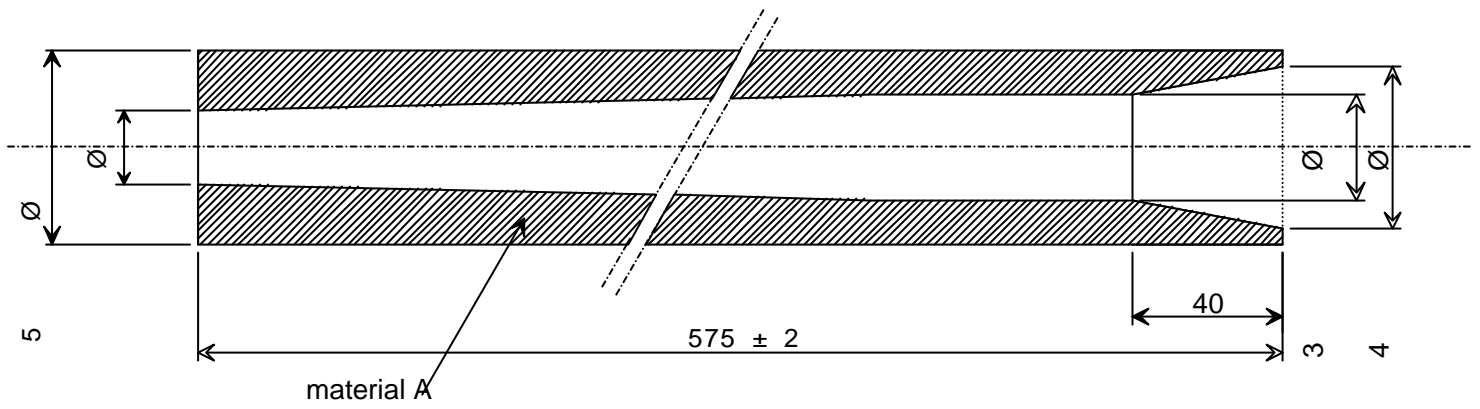
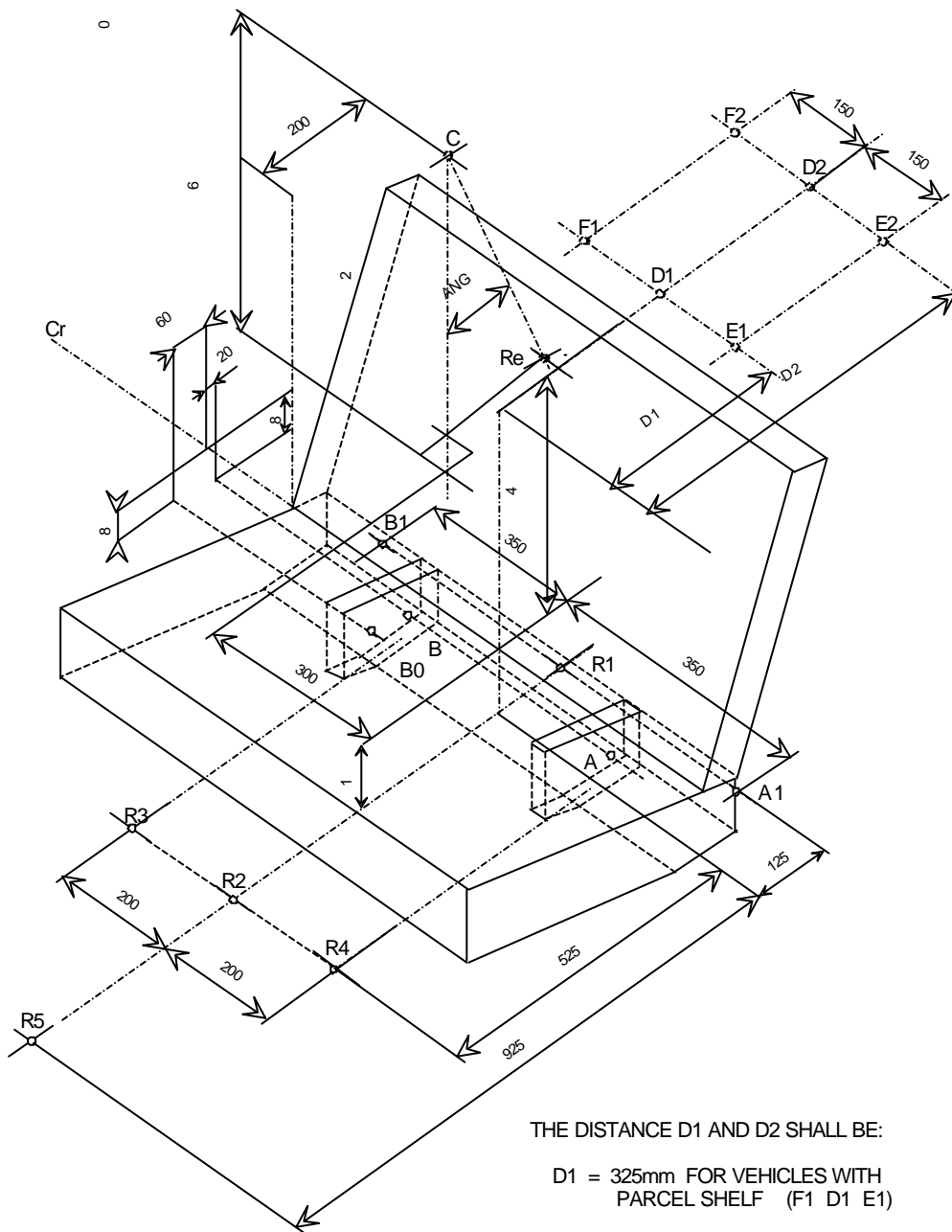

Figure 5

Annex 6 - Appendix 3

ARRANGEMENT AND USE OF ANCHORAGES ON THE TEST TROLLEY

1. The anchorages shall be positioned as shown in the figure below.
2. Child restraints in the "universal" and "restricted" categories shall use the following anchorage points:
 - 2.1. For child restraints approved for use with lap belts, points A and B;
 - 2.2. For child restraints approved for use with lap and diagonal belts, points A, B0, and C.
3. Anchorages A, B and D shall be used for child restraints in the "semi-universal" category having only one additional upper anchorage.
4. Anchorages A, B, E and F shall be used for child restraints in the "semi-universal" category having two additional upper anchorages.
5. Anchorage points R_1 , R_2 , R_3 , R_4 and R_5 are the additional anchorage points for rearward-facing child restraint systems in the "semi-universal" category having one or more additional anchorages (see paragraph 8.1.3.5.3.).
6. Except in the case of point C, (which represents the pillar loop position) the points, which correspond to the arrangement of the anchorages show where the ends of the belt are to be connected to the trolley or to the load transducer, as the case may be. The structure carrying the anchorages shall be rigid. The upper anchorages must not be displaced by more than 0.2 mm in the longitudinal direction when a load of 980 N is applied to them in that direction. The trolley shall be so constructed that no permanent deformation shall occur in the parts bearing the anchorages during the test.
7. For carry-cots in group 0, the points A_1 and/or B_1 can be used alternatively, as specified by the manufacturer of the restraint systems. A_1 and B_1 are located on a transverse line through R_1 at a distance of 350 mm from R_1 .
8. For testing of child restraints in the "universal" and "restricted" categories, a standard retractor belt, as specified in annex 13, shall be fitted to the test seat.



THE DISTANCE D1 AND D2 SHALL BE:

D1 = 325mm FOR VEHICLES WITH
 PARCEL SHELF (F1 D1 E1)

D1 = 1025mm FOR VEHICLES WITH
 FOLDING BACK REAR SEATS
 (ESTATE TYPE) (F2 D2 E2)

DIMENSIONS REFERRING TO Cr
 ARE TOLERANCED WITH: ± 2 mm

DISTANCE C - Re = 550mm

ANGLE "ANG" = 30° MAXIMUM

Figure 1

Annex 7

CURVE OF THE TROLLEY'S DECELERATION AS A FUNCTION OF TIME

1. The deceleration curve of the trolley weighted with inert masses to produce a total mass of 455 ± 20 kg in the case of child restraint tests performed in accordance with paragraph 8.1.3.1. of this Regulation, and of 910 ± 40 kg in the case of child restraint tests performed in accordance with paragraph 8.1.3.2. of this Regulation, where the nominal mass of the trolley and vehicle structure is 800 kg, must remain, in the case of frontal impact, within the hatched area shown in appendix 1 to this annex, and, in the case of rear impact, within the hatched area shown in appendix 2 to this annex.
2. If necessary, the nominal mass of the trolley and attached vehicle structure may be increased for each increment of 200 kg by an additional inert mass of 28 kg. In no case shall the total mass of the trolley and the vehicle structure and inert masses differ from the nominal value for calibration tests by more than ± 40 kg. During calibration of the stopping device, the stopping distance shall be 650 ± 30 mm for frontal impact, and 275 ± 20 mm for rear impact.
3. The calibration and measuring procedures shall correspond to those defined in the international standard ISO 6487 (1980), the measuring equipment shall correspond to the specification of a data channel, with a channel frequency class (CFC) 60.

Annex 7 - Appendix 1

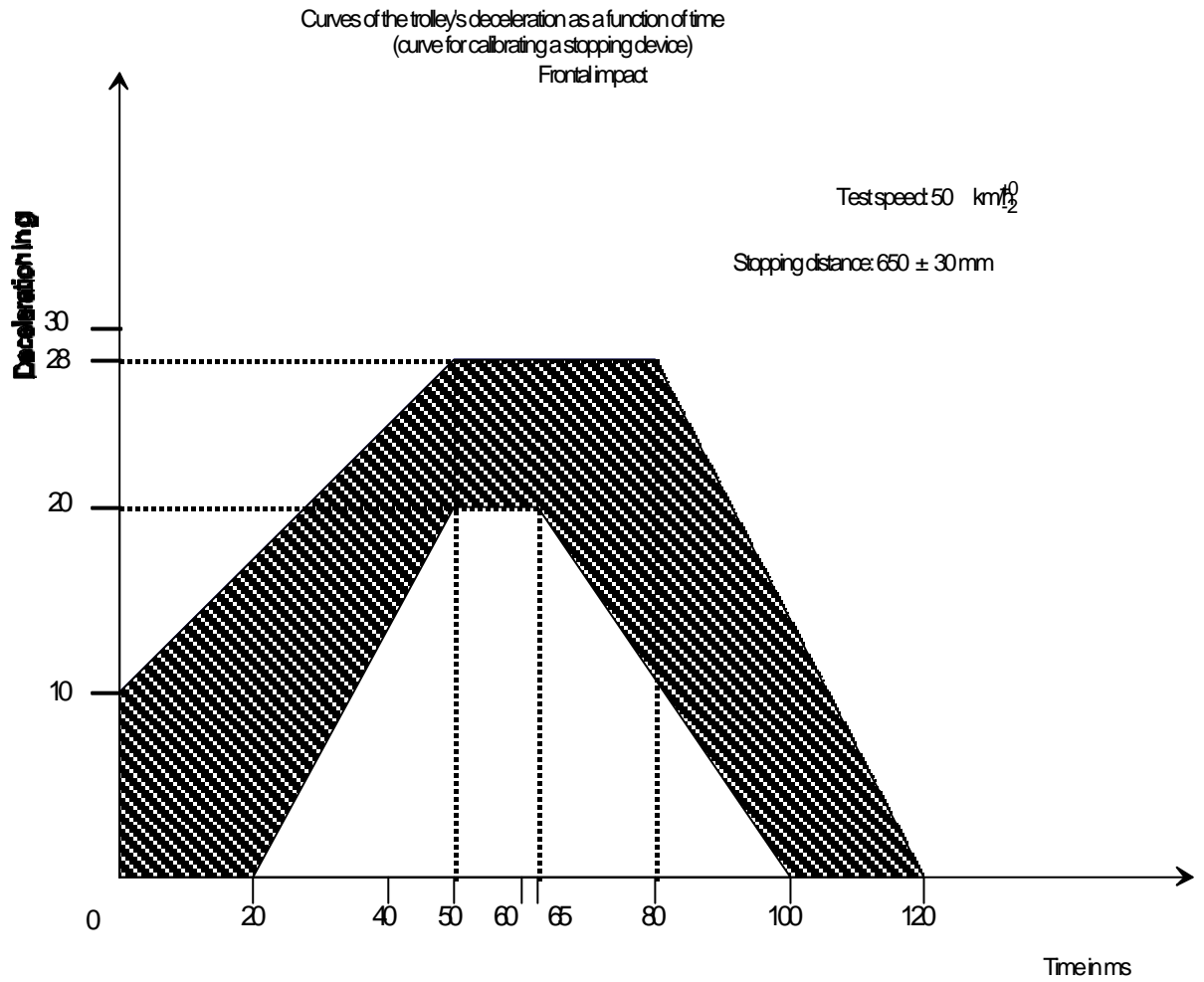

Annex 7 - Appendix 2

Curves of the trolley's deceleration as a function of time
(curve for calibrating a stopping device)
Rear impact

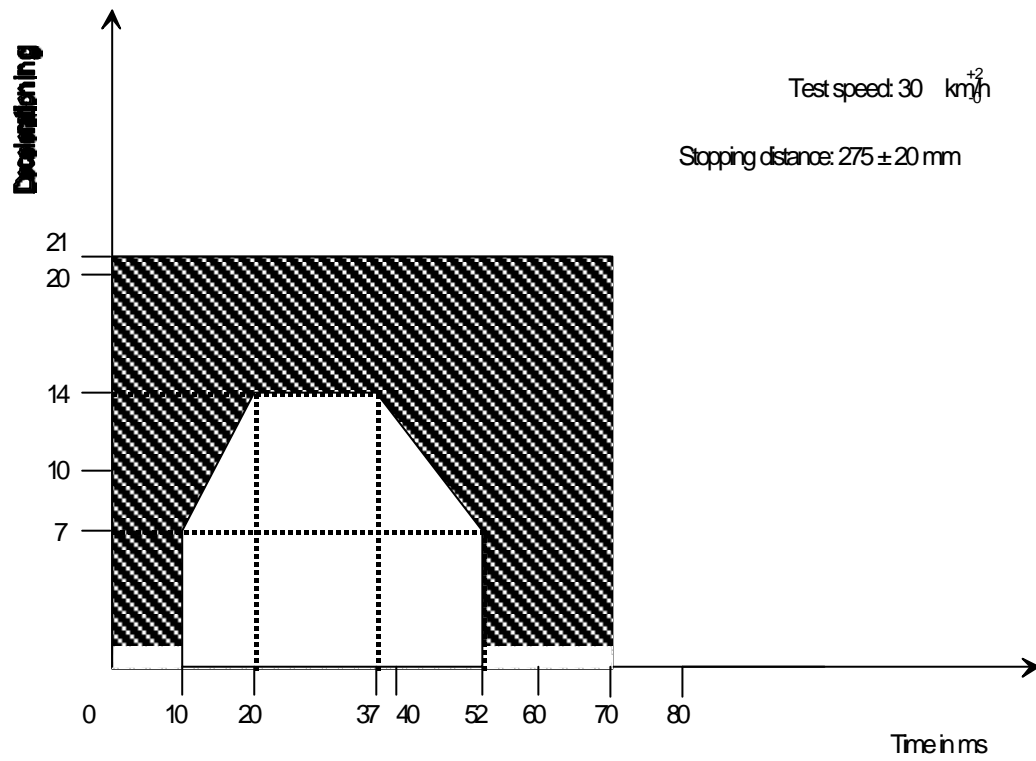

Annex 8

DESCRIPTION OF MANIKINS

1. General
 - 1.1. The manikins prescribed in this Regulation are described in appendices 1 to 3 to this annex, and in technical drawings produced by the TNO (Research Institute for Road Vehicles), Schoemakerstraat 97, 2628 VK Delft, The Netherlands.
 - 1.2. Alternative manikins may be used provided that:
 - 1.2.1. Their equivalence can be demonstrated to the satisfaction of the competent authority, and
 - 1.2.2. Their use is recorded in the test report, and in the communication form described in annex 1 to this Regulation.
-

Annex 8 - Appendix 1

DESCRIPTION OF THE 9 MONTHS AND 3, 6 AND 10-YEAR MANIKINS

1. General

The dimensions and masses of the manikins described below are based on the anthropometry of 50th percentile children aged 9 months and 3, 6 and 10 years respectively.

1.2. The manikins consist of a metal and polyester skeleton with cast polyurethane body components.

1.3. For an exploded view of the manikin, see Figure 9.

2. Construction

2.1. Head

2.1.1. The head is made of polyurethane and reinforced by metal strips. Inside the head it is possible to install measuring equipment on a polyamide block at the centre of gravity.

2.2. Vertebrae

2.2.1. Neck vertebrae

2.2.1.1. The neck is made of 5 rings of polyurethane containing a core of polyamide elements. The Atlas-Axis block is made of polyamide.

2.2.2. Lumbar vertebrae

2.2.2.1. The five lumbar vertebrae are made of polyamide.

2.3. Chest

2.3.1. The skeleton of the chest consists of a tubular steel frame on which the arm joints are mounted. The spine consists of a steel cable with four threaded terminals.

2.3.2. The skeleton is coated with polyurethane. Measuring equipment can be housed in the chest cavity.

2.4. Limbs

2.4.1. The arms and legs are also made of polyurethane, reinforced by metal elements in the form of square tubes, strips and plates. The knees and elbows are provided with adjustable hinge joints. The joints of the upper arm and upper leg consist of adjustable ball and socket joints.

2.5. Pelvis

2.5.1. The pelvis is made of glass reinforced polyester also coated with polyurethane.

2.5.2. The shape of the upper side of the pelvis, which is important for determining sensitivity to abdominal loading, is simulated as far as possible from the shape of a child's pelvis.

2.5.3. The hip joints are situated just below the pelvis.

2.6. Assembly of the manikin

2.6.1. Neck-chest-pelvis

2.6.1.1. The lumbar vertebrae and the pelvis are threaded on to the steel cable and their tension is adjusted by a nut. The neck vertebrae are mounted and adjusted in the same way. Since the steel cable must not be free to move through the chest, it must not be possible to adjust the tension of lumbar vertebrae from the neck or vice-versa.

2.6.2. Head-neck

2.6.2.1. The head may be mounted and adjusted by means of a bolt and nut through the Atlas-Axis block.

2.6.3. Torso-limbs

2.6.3.1. The arms and legs may be mounted and adjusted to the torso by means of ball and socket joints.

2.6.3.2. For the arm joints the balls are connected to the torso; in the case of the leg joints, they are connected to the legs.

3. Main characteristics

3.1. Mass

Table 1

Component	Mass in kg by age group			
	9 months	3 years	6 years	10 years
Head + neck	2.20 ± 0.10	2.70 ± 0.10	3.45 ± 0.10	3.60 ± 0.10
Torso	3.40 ± 0.10	5.80 ± 0.15	8.45 ± 0.20	12.30 ± 0.30
Upper arm (2x)	0.70 ± 0.05	1.10 ± 0.05	1.85 ± 0.10	2.00 ± 0.10
Lower arm (2x)	0.45 ± 0.05	0.70 ± 0.05	1.15 ± 0.05	1.60 ± 0.10
Upper leg (2x)	1.40 ± 0.05	3.00 ± 0.10	4.10 ± 0.15	7.50 ± 0.15
Lower leg (2x)	0.85 ± 0.05	1.70 ± 0.10	3.00 ± 0.10	5.00 ± 0.15
Total	9.00 ± 0.20	15.00 ± 0.30	22.00 ± 0.50	32.00 ± 0.70

3.2. Principal dimensions

3.2.1. The principal dimensions, based on figure 1 of this annex, are given in table 2.

Principal dimensions of manikin

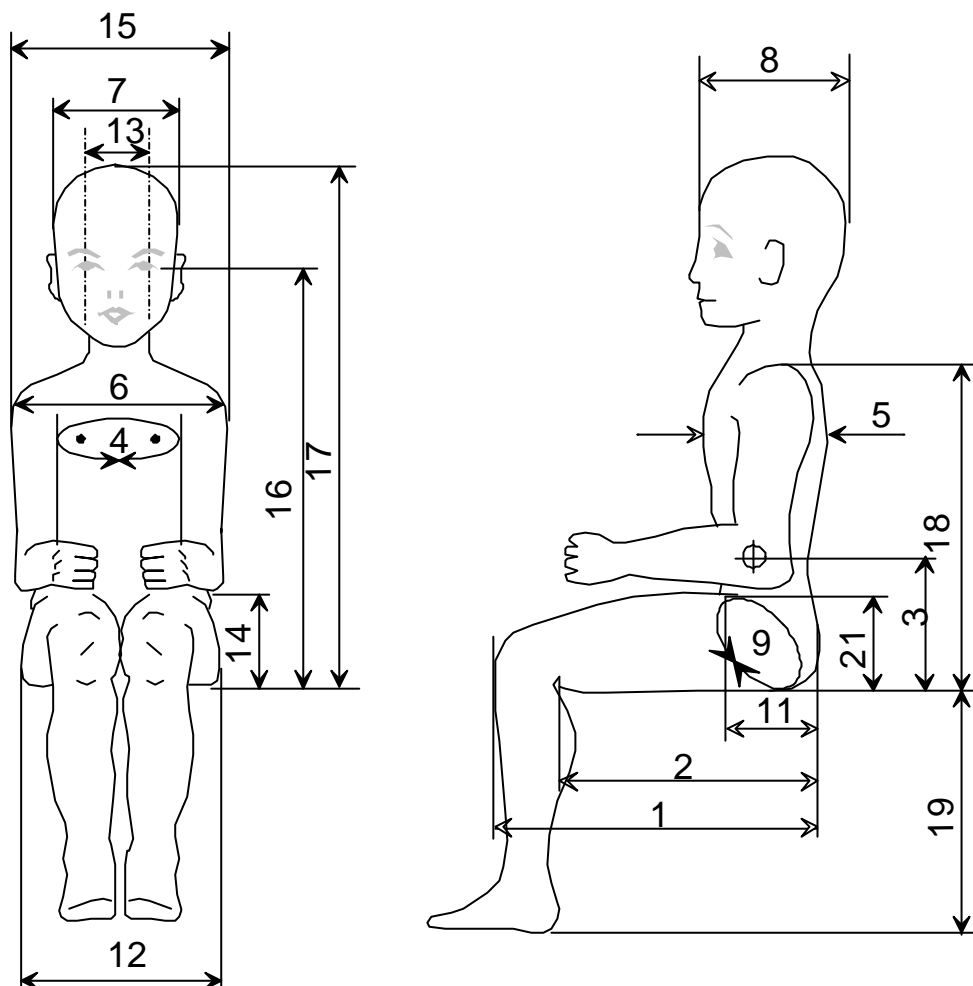

Figure 1

Table 2

No.	Dimensions	Dimensions in mm by age group			
		9 months	3 years	6 years	10 years
1	Back of buttocks to front knee	195	334	378	456
2	Back of buttocks to popliteus, sitting	145	262	312	376
3	Centre of gravity to seat	180	190	190	200
4	Chest circumference	440	510	580	660
5	Chest depth	102	125	135	142
6	Distance between shoulder blades	170	215	250	295
7	Head width	125	137	141	141
8	Head length	166	174	175	181
9	Hip circumference, sitting	510	590	668	780
10	Hip circumference, standing (not shown)	470	550	628	740
11	Hip depth, sitting	125	147	168	180
12	Hip width, sitting	166	206	229	255
13	Neck width	60	71	79	89
14	Seat to elbow	135	153	155	186
15	Shoulder width	216	249	295	345
16	Eye height sitting	350	460	536	625
17	Height, sitting	450	560	636	725
18	Shoulder height, sitting	280	335	403	483
19	Sole to popliteus, sitting	125	205	283	355
20	Stature (not shown)	708	980	1 166	1 376
21	Thigh height, sitting	70	85	95	106

4. Adjustment of joints

4.1. General

4.1.1. In order to achieve reproducible results using the manikins, it is essential to specify and adjust the friction in the various joints, the tension in the neck and lumbar cables, and the stiffness of the abdominal insert.

4.2. Adjustment of the neck cable

4.2.1. Place the torso on its back in a horizontal plane.

4.2.2. Mount the complete neck assembly without the head.

4.2.3. Tighten the tensioner nut on the Atlas-Axis block.

4.2.4. Place a suitable bar or bolt through the Atlas-Axis block.

4.2.5. Loosen the tensioner nut until the Atlas-Axis block is lowered by 10 ± 1 mm when a load of 50 N directed downwards is applied to the bar or bolt through the Atlas-Axis block (see figure 2).

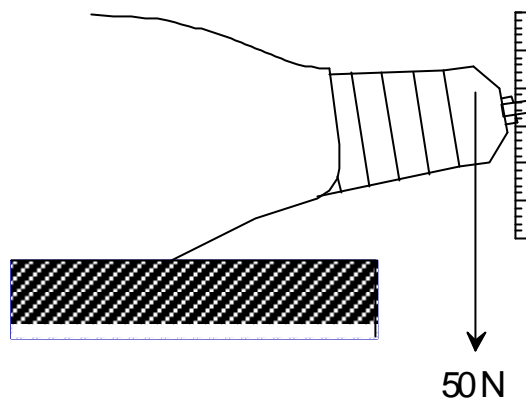

Figure 2

4.3. Atlas-Axis joint

4.3.1. Place the torso on its back in a horizontal plane.

4.3.2. Mount the complete neck and head assembly.

4.3.3. Tighten the bolt and adjustment nut through the head and the Atlas-Axis block with the head in a horizontal position.

4.3.4. Loosen the adjustment nut until the head starts moving (see figure 3).

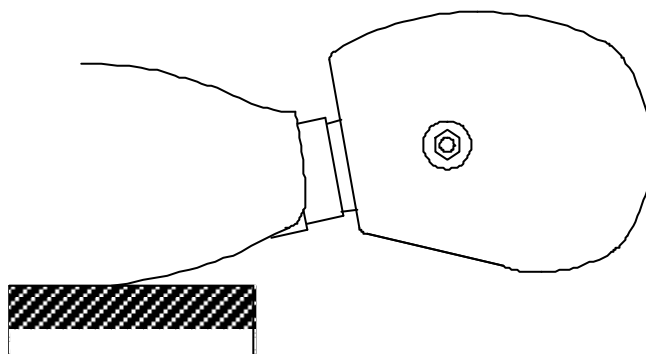

Figure 3

4.4. Hip joint

- 4.4.1. Place the pelvis on its front in a horizontal plane.
- 4.4.2. Mount the upper leg without the lower leg.
- 4.4.3. Tighten the adjustment nut with the upper leg in a horizontal position.
- 4.4.4. Loosen the adjustment nut until the upper leg starts moving.
- 4.4.5. The hip joint should be checked frequently in the initial stages because of "running-in" problems (see figure 4).

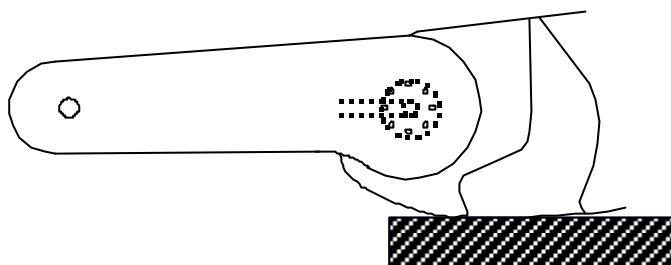

Figure 4

4.5. Knee joint

- 4.5.1. Place the upper leg in a horizontal position.
- 4.5.2. Mount the lower leg.
- 4.5.3. Tighten the adjustment nut of the knee joint with the lower leg in a horizontal position.
- 4.5.4. Loosen the adjustment nut until the lower leg starts moving (see figure 5).

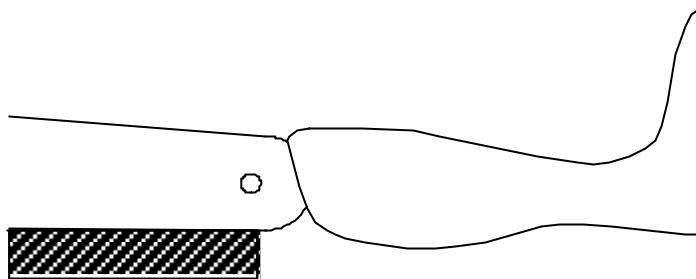

Figure 5

- 4.6. Shoulder joint
- 4.6.1. Place the torso upright.
- 4.6.2. Mount the upper arm without the lower arm.
- 4.6.3. Tighten the adjustment nuts of the shoulder with the upper arm in a horizontal position.
- 4.6.4. Loosen the adjustment nuts until the upper arm starts moving (see figure 6).
- 4.6.5. The shoulder joints should be checked frequently in the initial stages because of "running-in" problems.

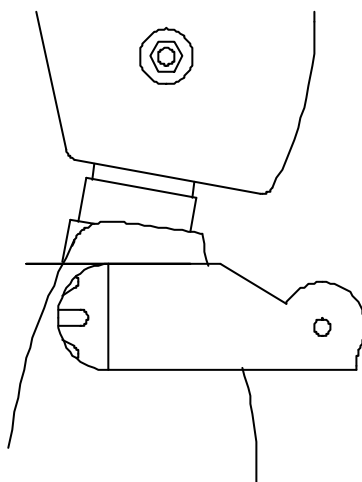

Figure 6

4.7. Elbow joint

- 4.7.1. Place the upper arm in a vertical position.
- 4.7.2. Mount the lower arm.
- 4.7.3. Tighten the adjustment nut of the elbow with the lower arm in a horizontal position.
- 4.7.4. Loosen the adjustment nut until the lower arm starts moving (see figure 7).

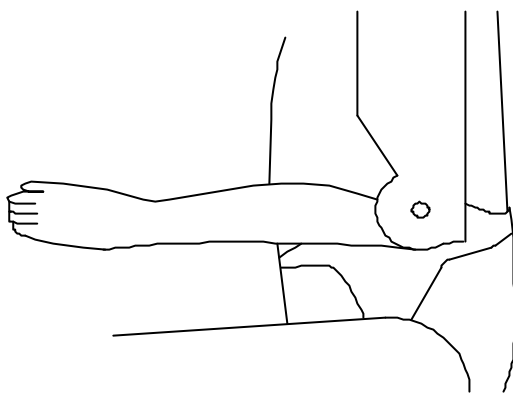

Figure 7

4.8. Lumbar cable

- 4.8.1. Assemble the upper torso, lumbar vertebrae, lower torso, abdominal insert, cable and spring.
- 4.8.2. Tighten the cable adjustment nut in the lower torso until the spring is compressed to $2/3$ of its unloaded length (see figure 8).

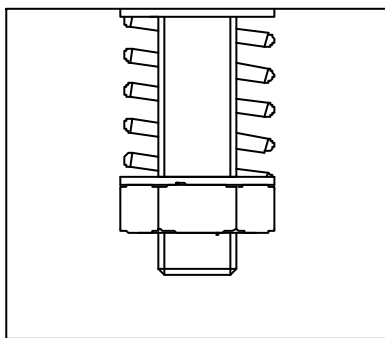

Figure 8

4.9. Calibration of the abdominal insert

4.9.1. General

4.9.1.1. The test shall be carried out by means of a suitable tension-producing machine.

4.9.2. Place the abdominal insert on a rigid block with the same length and width as the lumbar spinal column. The thickness of this block shall be at least twice the thickness of the lumbar spinal column (see figure 9).

4.9.3. An initial load of 20 N shall be applied.

4.9.4. A constant load of 50 N shall be applied.

4.9.5. The deflection of the abdominal insert after 2 minutes shall be:

for the 9 months dummy : 11.5 ± 2.0 mm
3 years dummy : 11.5 ± 2.0 mm
6 years dummy : 13.0 ± 2.0 mm
10 years dummy : 13.0 ± 2.0 mm

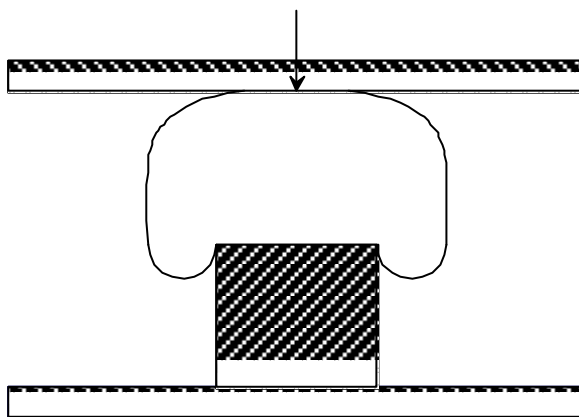

Figure 9

5. Instrumentation

5.1. General

5.1.1. The calibration and measuring procedures shall be based upon the international standards ISO 6487 (1980).

5.2. Installation of the accelerometer in the chest

The accelerometer shall be mounted in the protected cavity in the chest.

5.3. Indication of abdominal penetration

- 5.3.1. A sample of modelling clay shall be vertically connected to the front of the lumbar vertebrae by means of thin adhesive tape.
- 5.3.2. A deflection of the modelling clay does not necessarily mean that penetration has taken place.
- 5.3.3. The modelling clay samples shall be of the same length and width as the lumbar spinal column; the thickness of the samples shall be 25 ± 2 mm.
- 5.3.4. Only the modelling clay supplied with the manikins shall be used.
- 5.3.5. The temperature of the modelling clay during the test shall be 30 ± 5 EC.
-

Annex 8 - Appendix 2

DESCRIPTION OF THE "NEW-BORN" MANIKIN

The manikin comprises a head, torso, arms and legs as a single unit. The torso, arms and legs are a single moulding of Sorbothane covered with a PVC skin and containing a steel spring spine. The head is a polyurethane foam moulding covered by a PVC skin and is permanently attached to the torso. The manikin is provided with a close fitting stretch cotton/polyester suit.

The dimensions and mass distribution of the dummy are based on those of a 50th percentile new-born baby and are given in tables 1 and 2 and in figure 1.

Table 1 - PRINCIPAL DIMENSIONS OF THE "NEW-BORN" MANIKIN

Dimension		mm	Dimension		mm
A	Rump-Crown	345	E	Shoulder width	150
B	Rump - Sole (with straight leg)	250	F	Chest width	105
C	Head width	105	G	Chest depth	100
D	Head depth	125	H	Hip width	105
			I	C of G from top of head	235

Table 2 - MASS DISTRIBUTION OF THE "NEW-BORN" MANIKIN */

Head and neck	0.7 kg
Torso	1.1 kg
Arms	0.5 kg
Legs	1.1 kg
Total mass	3.4 kg

*/ The thickness of the PVC skin should be $1 + 0.5$ mm
 - 0
 The specific gravity should be 0.865 ± 0.1 .

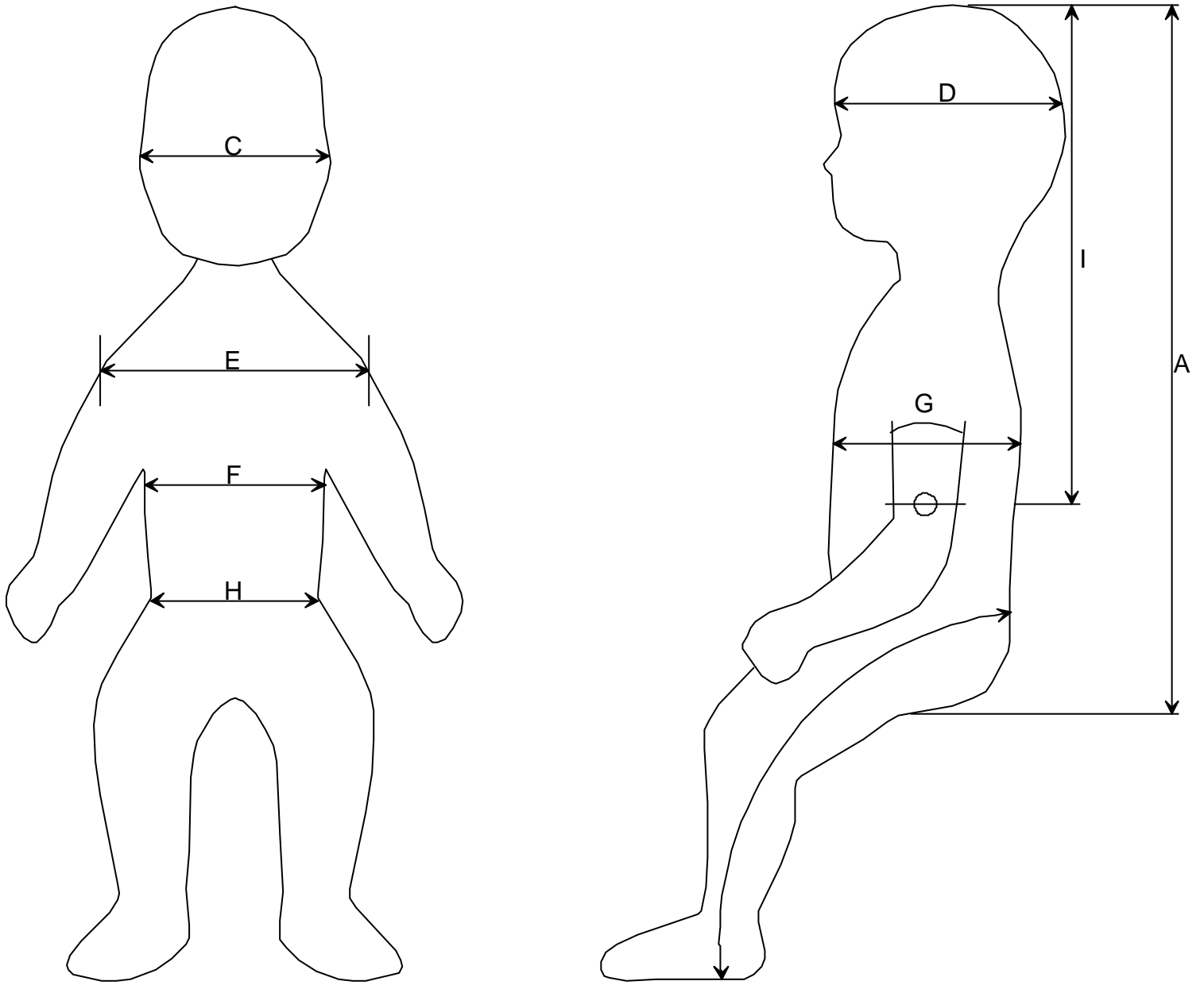

Figure 1

Calibration of infant manikin

1. Shoulder stiffness

- 1.1. Place manikin on its back on a horizontal surface and support torso on one side, to prevent movement. (Figure 2)
- 1.2. Apply a load of 150 N, on a 40 mm diameter flat faced plunger, horizontally, in a direction perpendicular to the manikin's superior-inferior axis. The axis of the plunger should be in the centre of the manikin's shoulder and adjacent to point A on the shoulder (see figure 2). The lateral deflection of the plunger from the point of first contact with the arm should be between 30 mm and 50 mm.
- 1.3. Repeat on the opposite shoulder - reversing the support.

2. Leg joint stiffness

- 2.1. Place manikin on its back on a horizontal plane (figure 3) and strap the two lower legs together, bringing the inside of the knee into contact.
- 2.2. Apply a vertical load over the knees with a 35 mm x 95 mm flat faced plunger with the centre line of the plunger over the highest point of the knees.
- 2.3. Apply sufficient force to the plunger to bend the hips until the face of the plunger is 85 mm above the support plane. This force should be between 30 N and 70 N. Ensure lower limbs do not contact any surface during the test.

3. Temperature

Calibration should be carried out of a temperature between 15EC and 30EC.

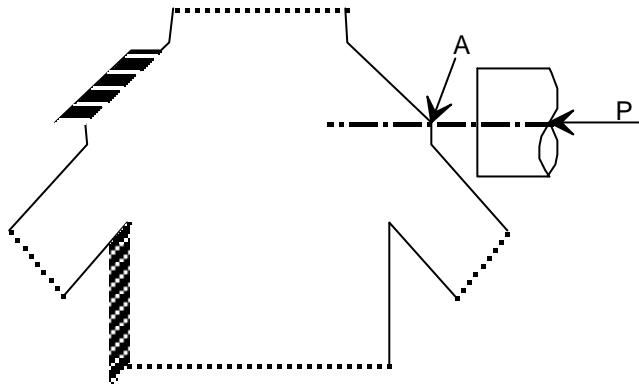

Figure 2

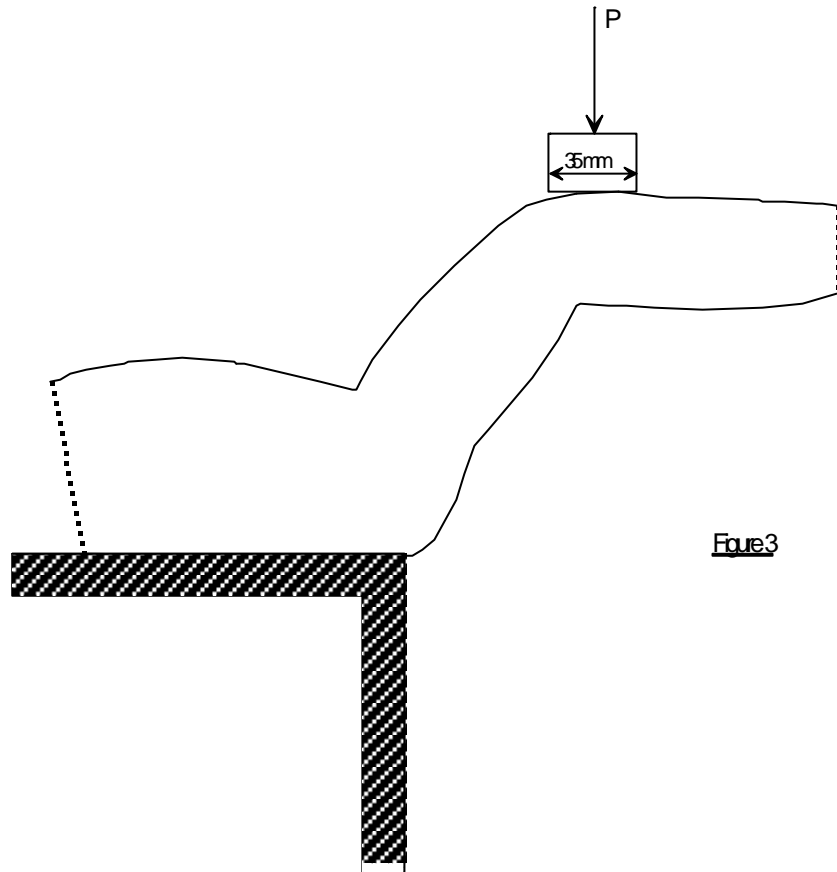

Figure 3

Annex 8 - Appendix 3

DESCRIPTION OF THE 18 MONTHS MANIKIN

1. General
- 1.1. The dimensions and masses of the manikin are based on the anthropometry of 50th percentile child, 18 months old.
2. Construction
- 2.1. Head
- 2.1.1. The head consists of a semi-rigid plastic skull covered with a head skin. The skull has a cavity which allows for the mounting of (optional) instrumentation.
- 2.2. Neck
- 2.2.1. The neck consists of three parts:
- 2.2.2. A solid rubber column,
- 2.2.3. An adjustable OC joint at the top of the rubber column, allowing rotation under adjustable friction around the lateral axis.
- 2.2.4. A non-adjustable spherical joint at the base of the neck.
- 2.3. Torso
- 2.3.1. The torso consists of a plastic skeleton, covered with a flesh/skin system. The torso has a cavity in front of the skeleton and accepts a foam filling to achieve the correct stiffness of the thorax. The torso has a cavity at the back which allows for the mounting of instrumentation.
- 2.4. Abdomen
- 2.4.1. The abdomen of the dummy is a one part deformable element which is inserted into the opening between the thorax and the pelvis.
- 2.5. Lumbar spine
- 2.5.1. The lumbar spine consists of a rubber column which is mounted between the thoracic skeleton and the pelvis. The stiffness of the lumbar spine is pre-set using a metal cable which runs through the hollow core of the rubber column.

2.6. Pelvis

2.6.1. The pelvis is made of a semi-rigid plastic, and is moulded in the shape of a child's pelvis. It is covered with a flesh skin system, simulating the flesh/skin around the pelvis and buttocks.

2.7. Hip joint

2.7.1. The hip joints mount to the lower part of the pelvis. The joint allows for rotation around a lateral axis as well as rotation around an axis at a right angle to the lateral axis using a gimbal joint. Adjustable friction applies to both axes.

2.8. Knee joint

2.8.1. The knee joint allows flexion and extension of the lower leg under adjustable friction.

2.9. Shoulder joint

2.9.1. The shoulder joint mounts to the thoracic skeleton. Click-stops allow the positioning of the arm in two initial positions.

2.10. Elbow joint

2.10.1. The elbow joint allows flexion and extension of the lower arm. Click-stops allow the positioning of the lower arm in two initial positions.

2.11. Assembly of the manikin

2.11.1. The spine cable is mounted in the lumbar spine.

2.11.2. The lumbar spine is mounted in the skeleton between the pelvis and the thoracic spine.

2.11.3. The abdominal insert is fitted between the thorax and the pelvis.

2.11.4. The neck is mounted on the top of the thorax.

2.11.5. The head is mounted on top of the neck using the interface plate.

2.11.6. The arms and legs are mounted.

3. Main characteristics

3.1. Mass

Table 1

Mass distribution of the 18 months manikin

Component	Mass (kg)
Head+neck	2.73
Torso	5.06
Upper arm	0.27
Lower arm	0.25
Upper leg	0.61
Lower leg	0.48
Total mass	11.01

3.2. Principal dimensions

3.2.1. The principal dimensions, based on figure 1 of this annex (reproduced below), are given in table 2.

Principal dimensions of manikin

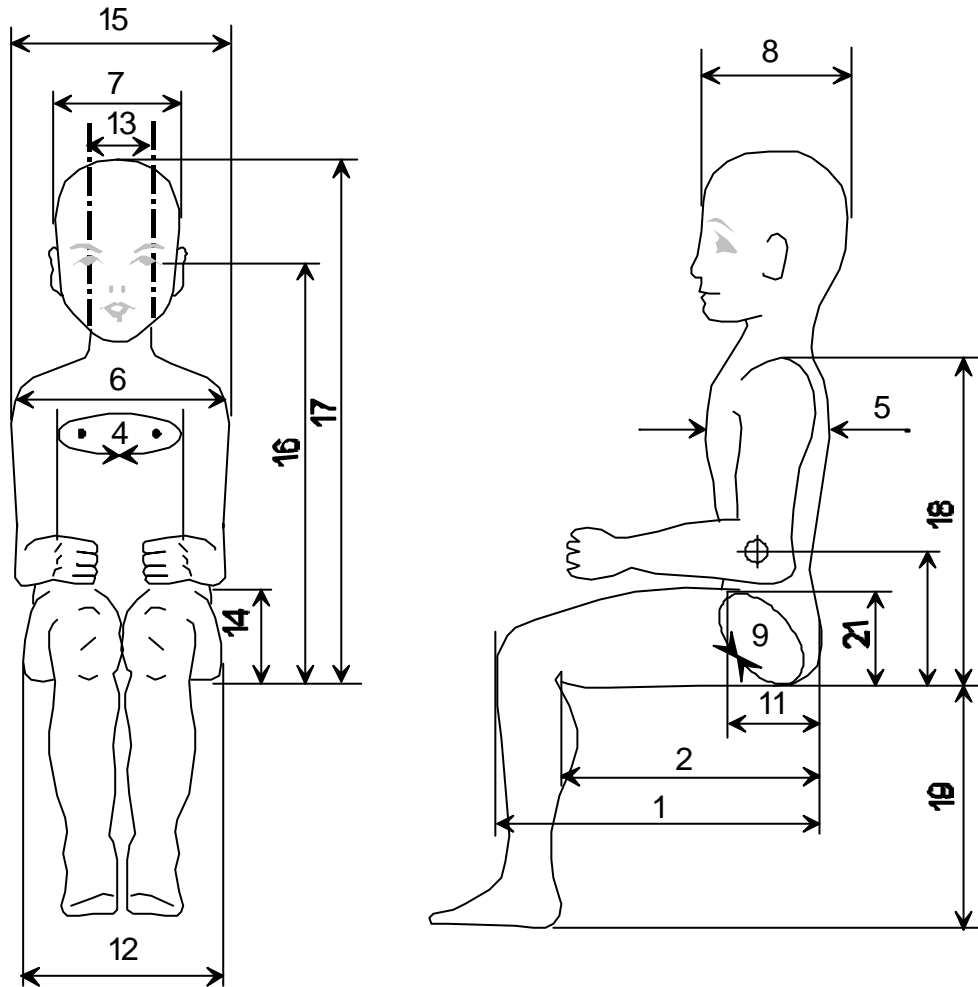

Figure 1

Principal dimensions of the 18 months manikin

Table 2

No.	Dimension	Value (mm)
1	Back of buttocks to front of knee	239
2	Back of buttocks to popliteus, sitting	201
3	Centre of gravity to seat	193
4	Chest circumference	474
5	Chest depth	113
7	Head width	124
8	Head length	160
9	Hip circumference, sitting	510
10	Hip circumference, standing (not shown)	471
11	Hip depth, sitting	125
12	Hip width, sitting	174
14	Seat to elbow	125
15	Shoulder width	224
17	Height, sitting	495 */
18	Shoulder height, sitting	305
19	Sole to popliteus, sitting	173
20	Stature (not shown)	820 */
21	Thigh height, sitting	66

*/ Manikin's buttocks, back and head resting against a vertical surface.

4. Adjustment of joints

4.1. General

4.1.1. In order to achieve reproducible results using the manikins, it is essential to adjust the friction in various joints, the tension in the lumbar spine, and the stiffness of the abdominal insert.

All parts must be checked for damage prior to these instructions.

4.2. Lumbar spine

4.2.1. The lumbar spine is calibrated before it is mounted in the dummy.

4.2.2. Attach the lower mounting plate of the lumbar spine to a setup such that the frontal side of the lumbar spine is located at the bottom (figure 2).

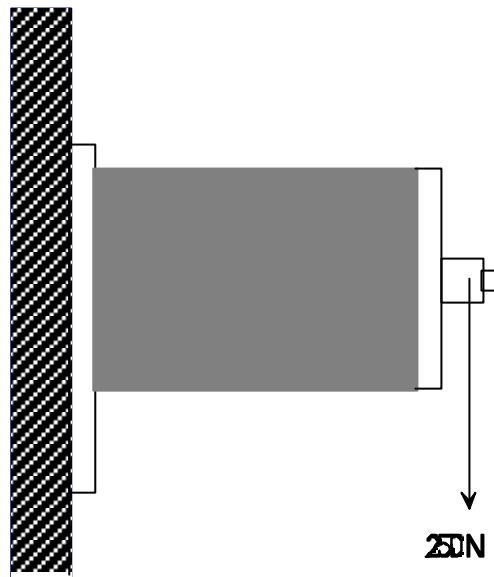

Figure 2

4.2.3. Apply a downward force of 250 N to the upper mounting plate. The resulting downward displacement should be recorded between 1 and 2 seconds after the onset of force application, and should be between 9 and 12 mm.

4.3. Abdomen

4.3.1. Mount the abdominal insert on a rigid block with the same length and width as the lumbar spine column. The thickness of this block shall be at least twice the thickness of the lumbar spine column (figure 3).

4.3.2. An initial load of 20 N shall be applied.

4.3.3. A constant load of 50 N shall be applied.

- 4.3.4. The deflection of the abdominal insert after two minutes shall be 12 ± 2 mm.

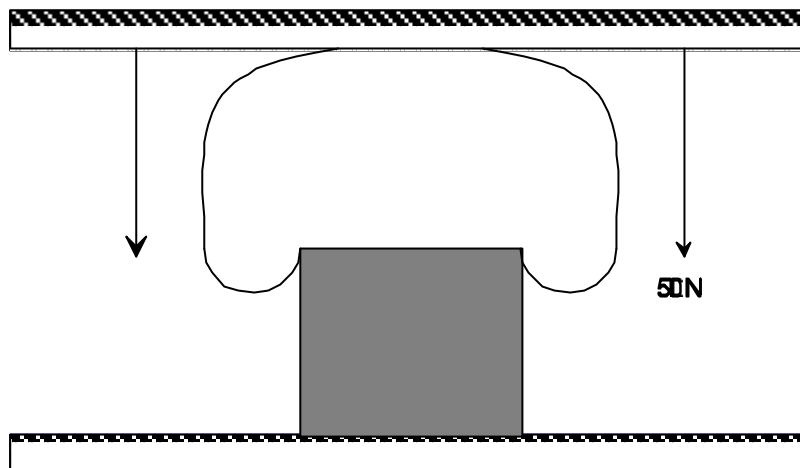

Figure 3

- 4.4. Adjustment of the neck
- 4.4.1. Mount the complete neck, consisting of the rubber column, spherical base joint and OC joint against a vertical surface such that the frontal side is facing downward (figure 4).

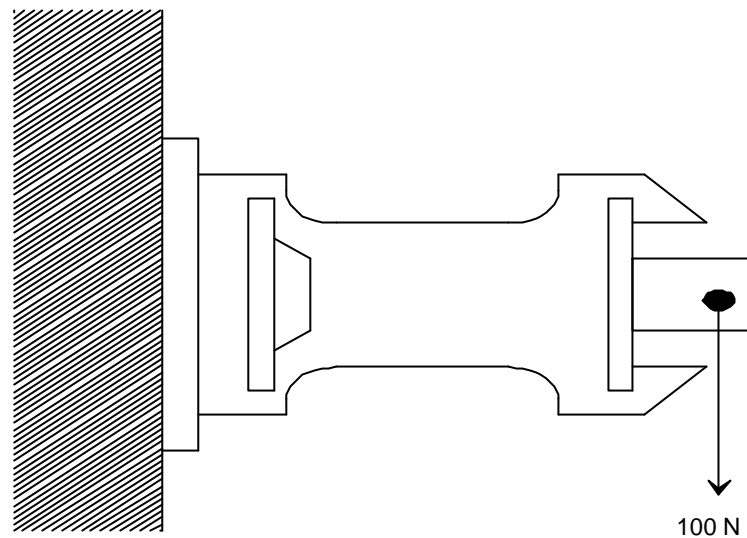

Figure 4

4.4.2. Apply a vertically directed force of 100 N on the axis of the OC joint. The position of the OC joint should display a downward displacement between 22 ± 2 mm.

4.5. OC Joint

4.5.1. Mount the complete neck and head assembly

4.5.2. Place the torso on its back in a horizontal plane.

4.5.3. Tighten the bolt and adjustment nut through the head and the OC joint using a torque wrench until the head is unable to move due to gravity.

4.6. Hip

4.6.1. Mount the upper leg, without the lower leg, to the pelvis.

4.6.2. Place the upper leg in a horizontal position.

4.6.3. Increase friction exerted on the lateral axis until the leg cannot move due to gravity.

4.6.4. Place the upper leg in a horizontal position, in the direction

of the lateral axis.

4.6.5. Increase friction at the gimbal joint until the upper leg does not move due to gravity.

4.7. Knee

4.7.1. Mount the lower leg to the upper leg.

4.7.2. Place the upper and lower legs in a horizontal position, with the upper leg supported.

4.7.3. Tighten the adjustment nut at the knee until the lower leg cannot move due to gravity.

4.8. Shoulders

4.8.1. Extend the lower arm and place the upper arm in the highest position it will click into.

4.8.2. The click-stops in the shoulder should be serviced or replaced if the arm does not remain in this position.

4.9. Elbow

4.9.1. Place the upper arm in the lowest position it will click into, and the lower arm in the upper click stop position.

4.9.2. The click-stops in the elbow should be serviced or replaced if the lower arm does not remain in this position.

5. Instrumentation

5.1. General

5.1.1. Although provisions have been made to equip the 18 months manikin with a number of transducers, it is standard equipped with replacements of equal size and weight.

5.1.2. The calibration and measuring procedures shall be based upon the international standard ISO 6487:1980.

5.2. Installation of the accelerometer in the chest

5.2.1. The accelerometer shall be mounted in the cavity in the chest.
This is done from the rear of the dummy.

5.3. Indication of abdominal penetration

5.3.1. The occurrence or absence of abdominal penetration must be
assessed using high speed photography.

Annex 9

FRONTAL IMPACT TEST AGAINST A BARRIER

1. Installations, procedure and measuring instruments

1.1. Testing ground

The test area shall be large enough to accommodate the run-up track, barrier and technical installations necessary for the test. The last part of the track, for at least 5 m before the barrier, must be horizontal, flat and smooth.

1.2. Barrier

The barrier consists of a block of reinforced concrete not less than 3 m wide at the front and not less than 1.5 m high. The barrier must be of such thickness that it weighs at least 70 tonnes. The front face must be vertical, perpendicular to the axis of the run-up track, and covered with plywood boards 20 ± 1 mm thick in good condition. The barrier shall be either anchored in the ground or placed on the ground with, if necessary, additional arresting devices to limit its displacement. A barrier with different characteristics, but giving results at least equally conclusive, may likewise be used.

1.3. Propulsion of the vehicle

At the moment of impact, the vehicle must no longer be subjected to the action of any additional steering or propelling device or devices. It must reach the obstacle on a course perpendicular to the collision wall; the maximum lateral disalignment permitted between the vertical median line of the front of the vehicle and the vertical median line of the collision wall is ± 30 cm.

1.4. State of the vehicle

- 1.4.1. The vehicle under test must either be fitted with all the normal components and equipment included in its unladen service weight or be in such a condition as to fulfil this requirement in so far as the components and equipment of concern to the passenger compartment and the distribution of the service weight of the vehicle as a whole are concerned.

- 1.4.2. If the vehicle is driven by external means, the fuel installation must be filled to at least 90 per cent of its capacity, either with fuel or with a non-inflammable liquid, having a density and a viscosity close to those of the fuel normally used. All other systems (brake-fluid containers, radiator, etc.) must be empty.
- 1.4.3. If the vehicle is driven by its own engine, the fuel tank must be at least 90 per cent full. All other liquid-holding tanks must be filled to capacity.
- 1.4.4. If the manufacturer so requests, the technical service responsible for conducting the tests may allow the same vehicle as is used for tests prescribed by other Regulations (including tests capable of affecting its structure) to be used also for the tests prescribed by this Regulation.

1.5. Impact velocity

The impact velocity must be 50 +0/-2 km/h. However, if the test has been carried out at a higher impact velocity and the vehicle has satisfied the conditions prescribed, the test is considered satisfactory.

1.6. Measuring instruments

The instrument used to record the speed referred to in paragraph 1.5. above shall be accurate within 1 per cent.

Annex 10

REAR IMPACT TEST PROCEDURE

1. Installations, procedures and measuring instruments

1.1. Testing ground

The test area shall be large enough to accommodate the propulsion system of the impactor and to permit after-impact displacement of the vehicle impacted and installation of the test equipment. The part in which vehicle impact and displacement occur shall be horizontal. (The slope shall be less than 3 per cent measured over any length of one metre.)

1.2. Impactor

1.2.1. The impactor shall be of steel and of rigid construction.

1.2.2. The impacting surface shall be flat and at least 2,500 mm wide and 800 mm high. Its edges shall be rounded to a radius of curvature of between 40 and 50 mm. It shall be clad with a layer of plywood 20 ± 1 mm thick.

1.2.3. At the moment of impact the following requirements shall be met:

1.2.3.1. the impacting surface shall be vertical and perpendicular to the median longitudinal plane of the impacted vehicle;

1.2.3.2. the direction of movement of the impactor shall be substantially horizontal and parallel to the median longitudinal plane of the impacted vehicle;

1.2.3.3. the maximum lateral deviation permitted between the median vertical line of the surface of the impactor and the median longitudinal plane of the impacted vehicle shall be 300 mm. In addition, the impacting surface shall extend over the entire width of the impacted vehicle;

1.2.3.4. the ground clearance of the lower edge of the impacting surface shall be 175 ± 25 mm.

1.3. Propulsion of the impactor

The impactor may either be secured to a carriage (moving barrier) or form part of a pendulum.

1.4. Special provisions applicable where a moving barrier is used

1.4.1. If the impactor is secured to a carriage (moving barrier) by a restraining element, the latter must be rigid and be incapable of being deformed by the impact; the carriage shall, at the moment of impact, be capable of moving freely and no longer be subject to the action of the propelling device.

1.4.2. The combined mass of carriage and impactor shall be $1,100 \pm 20$ kg.

1.5. Special provisions applicable where a pendulum is used

1.5.1. The distance between the centre of the impacting surface and the axis of rotation of the pendulum shall be not less than 5 m.

1.5.2. The impactor shall be freely suspended by rigid arms, rigidly secured to it. The pendulum so constituted shall be substantially incapable of being deformed by the impact.

1.5.3. A stopping device shall be incorporated in the pendulum to prevent any secondary impact by the impactor on the test vehicle.

1.5.4. At the moment of impact, the velocity of the centre of percussion of the pendulum shall be between 30 and 32 km/h.

1.5.5. The reduced mass " m_r " at the centre of percussion of the pendulum is defined as a function of the total mass " m ", of the distance " a " ^{*}/ between the centre of percussion and the axis of rotation, and of the distance " l " between the centre of gravity and the axis of rotation, by the following equation:

$$m_r = m \cdot \frac{l}{a}$$

^{*}/ The distance " a " is equal to the length of the synchronous pendulum under consideration.

1.5.6. The reduced mass "m_r" shall be 1,100 ± 20 kg.

1.6. General provisions relating to the mass and velocity of the impactor

If the test has been conducted at an impact velocity higher than those prescribed in paragraph 1.5.4. and/or with a mass greater than those prescribed in paragraphs 1.5.3. or 1.5.6., and the vehicle has met the requirements prescribed, the test shall be considered satisfactory.

1.7. State of the vehicle during the test

The vehicle being tested shall either be fitted with all the normal components and equipment included in its unladen service weight or be in such condition as to fulfil this requirement in so far as the distribution of the service weight of the vehicle as a whole is concerned.

1.8. The complete vehicle with the child restraint installed in accordance with the fitting instructions shall be placed on a hard, flat and level surface, with the handbrake off and in neutral gear. More than one child restraint may be tested in the same impact test.

Annex 11

ADDITIONAL ANCHORAGES REQUIRED FOR ATTACHING CHILD RESTRAINTS
IN THE SEMI-UNIVERSAL CATEGORY TO MOTOR VEHICLES

1. This annex applies only to the additional anchorages for attaching child restraints in the "semi-universal" category or to bars or other special items used to secure child restraining devices to the bodywork, whether or not they make use of the Regulation No. 14 anchorages.
2. The anchorages shall be determined by the manufacturer of the child restraint and details shall be submitted for approval to the technical service conducting the tests.

The technical services may take into account information obtained from the vehicle manufacturer.

3. The manufacturer of the child restraint shall provide the necessary parts for fitting the anchorages and a special plan for each vehicle showing their exact location.
4. The child restraint manufacturer shall indicate if the anchorages required for attaching the restraint to the car structure are in accordance with the position and strength requirements of paragraph 3 onwards in the recommendation given to Governments intending to adopt specific requirements relating to anchorages for child restraints used in passenger cars. 1/

1/ See text of paragraph 1.13. and of annex 10 of the Consolidated Resolution on the Construction of Vehicles (R.E.3) (TRANS/WP.29/78/Rev.1).

Annex 12

Chair

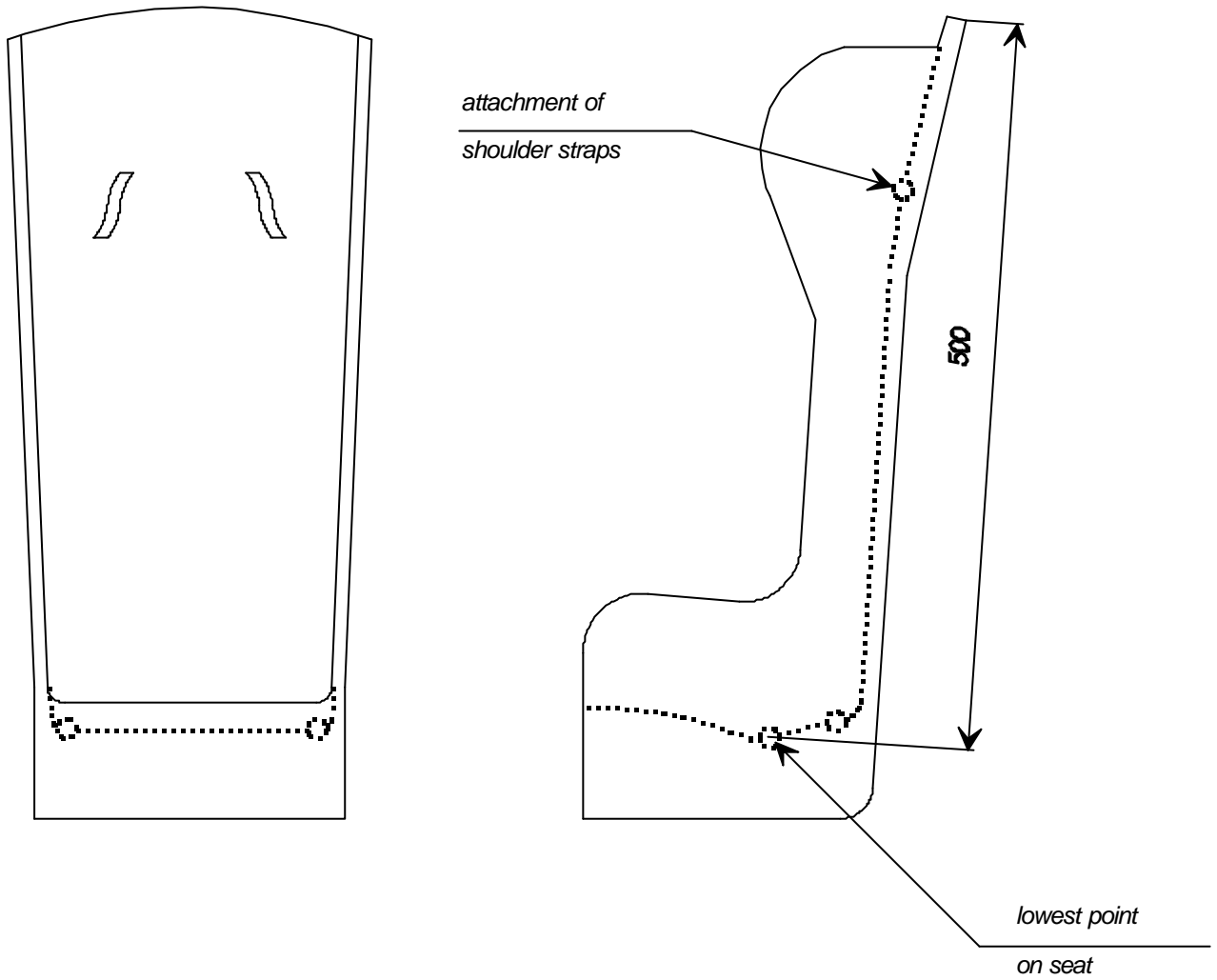

dimensions in mm

Annex 13

STANDARD SAFETY-BELT

1. The safety-belt for the dynamic test and for the maximum length requirement shall be made to one of the two configurations shown in Figure 1. These are a three-point retracting belt and a two-point static belt.
2. The three-point retracting belt has the following rigid parts: a retractor (R), a pillar loop (P), two anchorage points (A1 and A2, see Figure 2) and a central part (C, see Figure 3). The retractor shall comply with the requirements of Regulation No. 16 for retraction force. The retractor spool diameter is 33 ± 0.5 mm.
3. The retracting belt shall be fitted to the anchorages on the test seat, described in annex 6, appendices 1 and 4, as follows:

Belt anchorage A1 shall be fitted to trolley anchorage B0 (outboard)
Belt anchorage A2 shall be fitted to trolley anchorage A (inboard)
Belt pillar loop P shall be fitted to trolley anchorage C.
Belt retractor R shall be fitted to trolley anchorage Re.

The value of X in Figure 1 below is 215 ± 5 mm. The value of P-A1 in Figure 1 below for "universal" and "semi-universal" child restraints is $2,190 \pm 5$ mm, measured parallel to the centreline of the strap with 150 ± 5 mm of strap on the spool of the retractor. The value of P-A1 for "restricted" child restraints is at least 2,190 mm, measured parallel to the strap centreline with 150 ± 5 mm of strap on the spool of the retractor.
4. The strap requirements for the belt are as follows:

Material: polyester spinnblack - width: 48 ± 2 mm at 10,000 N
- thickness: 1.0 ± 0.2 mm
- elongation: 8 ± 2 % at 10,000 N
5. The two-point static belt as shown in Figure 1 consists of two standard anchorage plates as shown in Figure 2 and a strap fulfilling the requirements of paragraph 4 above.
6. The two-point belt anchorage plates shall be fitted to trolley anchorages A and B. The value of Y in Figure 1 is $1,300 \pm 5$ mm. This is the maximum length requirement for the approval of universal child restraints with two-point belts (see para. 6.1.9.)

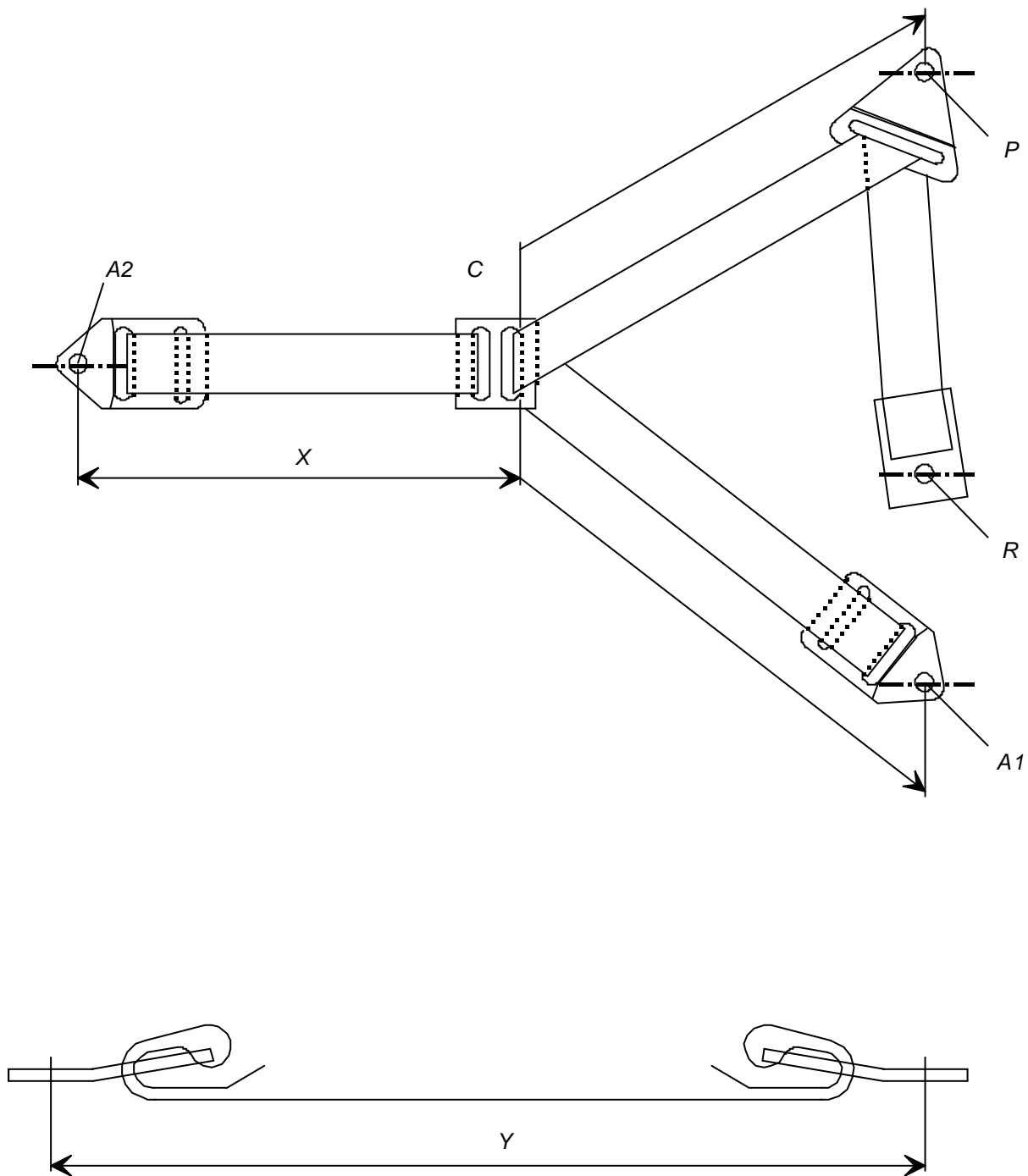

Figure 1: Standard seat belt configurations

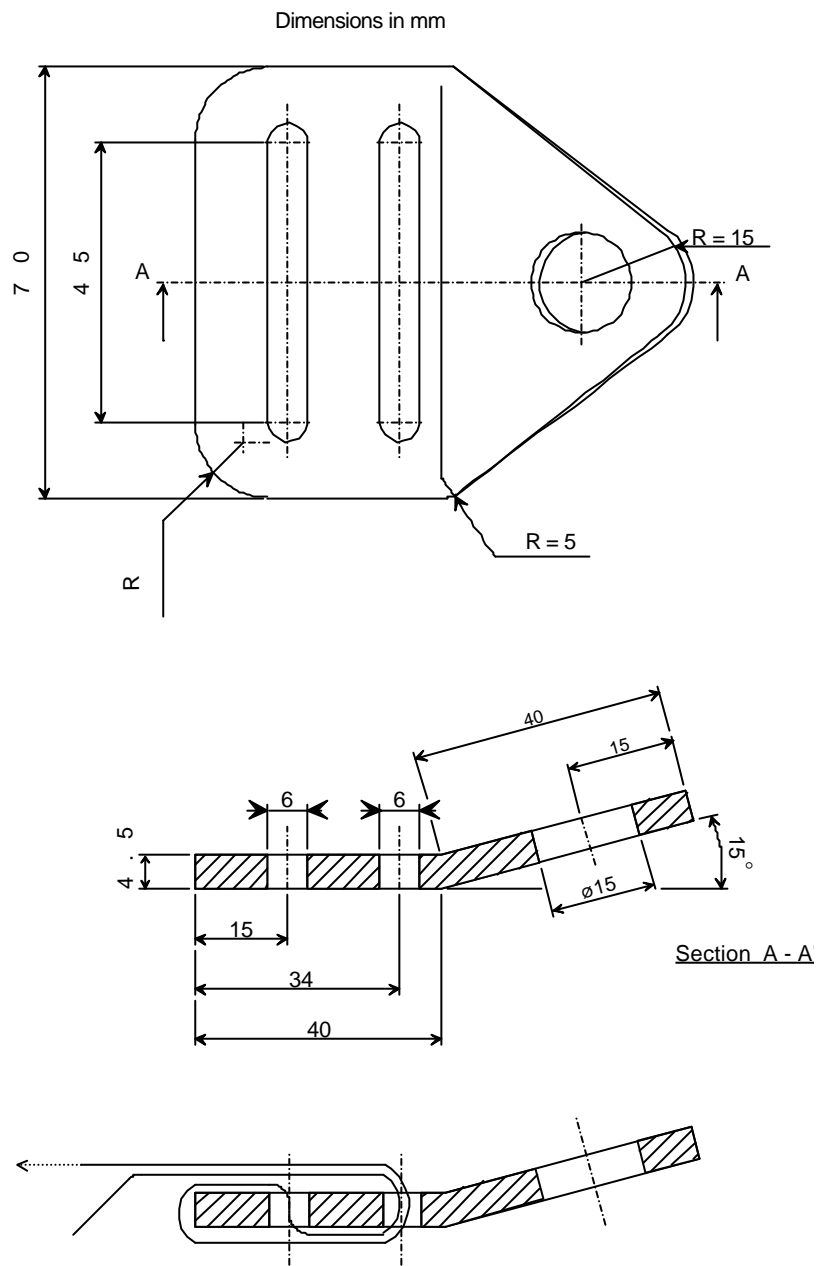

Figure 2: Typical standard anchorage plate

Dimensions in mm

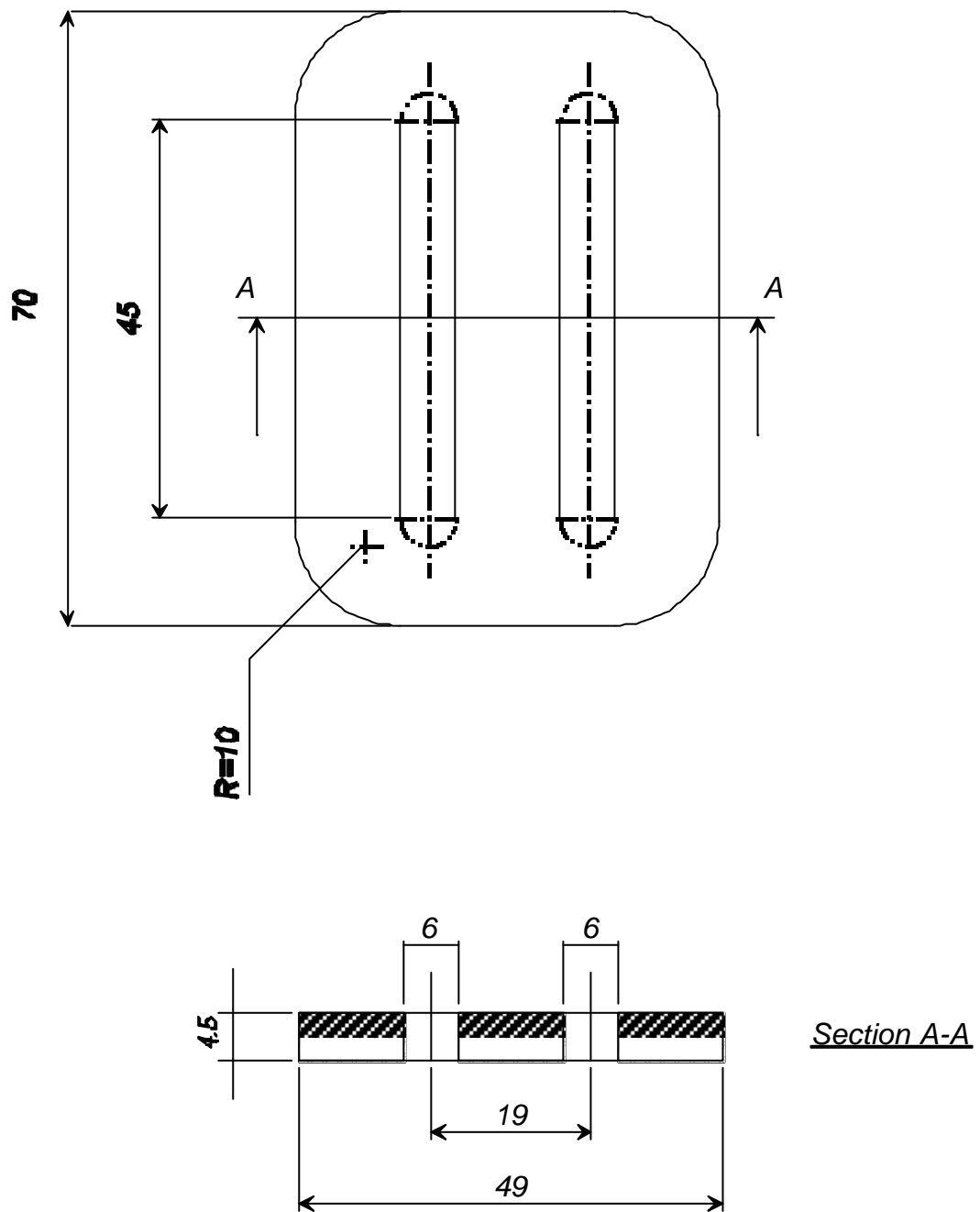

Figure 3: Central part of the standard belt configuration

Finish: Chromium plated

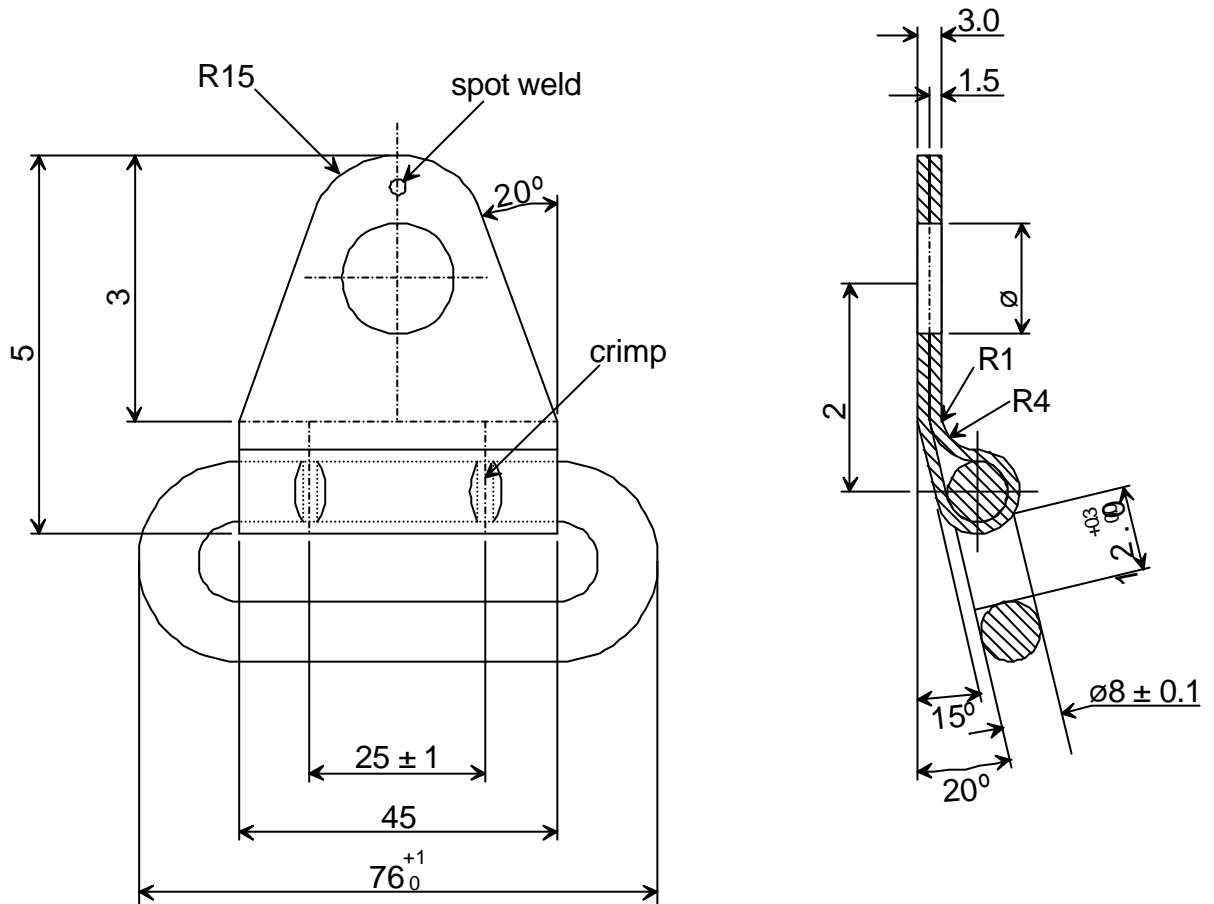

Figure 4: Pillar loop

Annex 14

(Not used - for the text of the former annex 14, see annex 8 - appendix 2)

Annex 15

EXPLANATORY NOTES

The explanatory notes given in this annex concern interpretation difficulties with the Regulation. They are meant as a guide for the technical services performing the tests.

Paragraph 2.10.1.

A quick adjuster can also be a device with a rotation shaft and spring similar to a retractor with a manual release. The adjuster should be tested to the requirements of paragraphs 7.2.2.5. and 7.2.3.1.3.

Paragraph 2.19.2.

A semi-universal restraint specified for fitting to the rear seat in both a saloon and an estate type vehicle in which the whole belt assembly is identical is one 'type'.

Paragraph 2.19.3.

The significance of changes in the dimensions and/or mass of the seat, padding or impact shield and the energy-absorbing characteristics or colour of the material are to be considered when deciding whether a new type has been created.

Paragraphs 2.19.4. and 2.19.5.

These paragraphs shall not apply to any safety belts separately approved in accordance with Regulation No. 16 which is necessary to anchor the child restraint to the vehicle or to restrain the child.

Paragraph 6.1.2.

For rearward-facing child restraints the correct position of the top of the restraint relative to the child dummy head is ensured by installing the largest dummy, for which the device was specified, in the most reclined configuration, and making sure that a horizontal line at the eye height passes below the top of the seat.

Paragraph 6.2.4.

This shall be assessed by examination of the high-speed film results where visible penetration of the abdomen by any part of the restraint or riding up of any lap strap onto the chest, shall constitute a failure. (Twisting of the dummy out of the shoulder strap before the point of maximum displacement shall itself also be considered as a failure, but at the manufacturer's request two further tests may be performed with the appropriate dummy. All test requirements must be met in full during these tests.)

Paragraph 7.1.2.1. and annexes 17 and 18

Either energy absorbing material, or the integral material of the child restraint structure can be tested for compliance with annexes 17 and 18, where the structure is not homogeneous, or if there is likely to be varying performance over the child restraint system structure, the testing organization will determine the worst case for testing compliance. The energy absorbing material may form the whole or part of the child restraint system cover.

Paragraph 7.1.3.

The overturning test will be conducted using the same installation procedure and parameters as those defined for the dynamic test.

Paragraph 7.1.3.1.

Stopping of the rig during the overturning is not allowed.

Paragraph 7.1.4.2.2.

The wording of this paragraph refers to accelerations representing tensile loads in the spine of the dummy.

Paragraph 7.1.4.3.1.

Visible signs of penetration means penetration of the clay by the abdominal insert (under pressure from the restraint) but not bending of the clay without compression in a horizontal direction as for instance is brought about by simple bending of the spine. See also interpretation of paragraph 6.2.4.

Paragraph 7.2.1.5.

The first sentence is complied with if the hand of the dummy could reach the buckle.

Paragraph 7.2.2.1.

This shall be used to ensure that separately approved guide-straps shall be easily attached and detached.

Paragraph 7.2.4.1.1.

Two straps are required. Measure the breaking load of the first strap. Measure the width of the second strap at 75 per cent of this load.

Paragraph 7.2.4.4.

Items which may be disassembled or unthreaded and where incorrect reassembly is probable for an untrained user and could result in a dangerous configuration shall not be allowed.

Paragraph 8.1.2.2.

'Fastened to the seat' means the test seat as prescribed in annex 6. 'Specific devices may' means that a 'specific' restraint would normally be tested for overturning when installed in the test seat, but that testing in the vehicle seat was allowed.

Paragraph 8.2.2.1.1.

'Having regard to normal conditions of use' means that this test should be performed with the restraint mounted on the test or vehicle seat but without the dummy.

The dummy shall be used only to position the adjusting device. In the first instance the straps should be adjusted in accordance with paragraphs 8.1.3.6.3.2. or 8.1.3.6.3.3. (whichever is appropriate). The test should then be conducted after removal of the dummy.

Paragraph 8.2.5.2.6.

This paragraph shall not apply to guide straps which are approved separately under this Regulation.

CONTROL OF CONFORMITY OF PRODUCTION

1. Tests

Child restraint systems shall be required to demonstrate compliance with the requirements on which the following tests are based:

1.1. Verification of the locking threshold and durability of emergency locking retractors

According to the provisions of paragraph 8.2.4.3. in the most unfavourable direction as appropriate after having undergone the durability testing detailed in paragraphs 8.2.4.2., 8.2.4.4. and 8.2.4.5. as a requirement of paragraph 7.2.3.2.6.

1.2. Verification of the durability of automatically locking retractors

According to the provisions of paragraph 8.2.4.2. supplemented by the tests in paragraphs 8.2.4.4. and 8.2.4.5. as a requirement of paragraph 7.2.3.1.3.

1.3. Test for strength of straps after conditioning

According to the procedure described in paragraph 7.2.4.2. after conditioning according to the requirements of paragraphs 8.2.5.2.1. to 8.2.5.2.5.

1.3.1. Test for strength of straps after abrasion

According to the procedure described in paragraph 7.2.4.2. after conditioning according to the requirements described in paragraph 8.2.5.2.6.

1.4. Microslip test

According to the procedure described in paragraph 8.2.3. of this Regulation.

1.5. Energy absorption

According to the provisions of paragraph 7.1.2. of this Regulation.

1.6. Verification of the performance requirements of the child restraint system when subjected to the appropriate dynamic test

According to the provisions set out in paragraph 8.1.3. with any buckle having been pre-conditioned according to the requirements of paragraph 7.2.1.7. such that the appropriate requirements of paragraph 7.1.4. (for the overall performance of the child restraint) and paragraph 7.2.1.8.1. (for the performance of any buckle under load) are complied with.

2. Test frequency and results

2.1. The frequency of testing to the requirements of paragraphs 1.1. to 1.5. shall be on a statistically controlled and random basis in accordance with one of the regular quality assurance procedure.

2.1.1. Furthermore, in the case where emergency locking retractors are incorporated in the child restraint system, all such assemblies shall be checked:

2.1.1.1. either according to the provisions set out in paragraphs 8.2.4.3.1., 8.2.4.3.2., 8.2.4.3.3. and 8.2.4.3.4. of this Regulation, in the most unfavourable direction as specified in paragraph 8.2.4.3.3. Test results shall meet the requirements of paragraphs 7.2.3.2.1.1. and 7.2.3.2.4. of this Regulation,

2.1.1.2. or according to the provisions set out in paragraph 8.2.4.3.5. of this Regulation, in the most unfavourable direction. Nevertheless, the speed of inclination can be more than the prescribed speed in so far as it does not affect the test results. Test results shall meet the requirements of paragraph 7.2.3.2.1.4. of this Regulation.

2.2. For "universal", "restricted" and "semi-universal" devices, the minimum frequency in order to verify compliance with the dynamic test according to paragraph 1.6. shall be 1 in 5,000 child restraint systems produced. However, in any case there shall be at least one test performed for each four weeks of production.

The requirements set out in paragraphs 7.1.4.1.4. and 7.2.1.8.1.2. of this Regulation shall be met for each test. Furthermore for one test out of two, the other requirements set

out in paragraphs 7.1.4. and 7.2.1.8.1. shall be met also.

However a minimum frequency of one test per year shall be permitted where annual production is 1,000 child restraint systems or less.

In this case the requirements set out in paragraphs 7.1.4. and 7.2.1.8.1. shall be met.

- 2.3. For "built-in" vehicle specific devices, the following test frequencies shall apply:

Child restraints, except booster cushions: Once every 8 weeks
Booster cushions: Once every 12 weeks

At each test all requirements according to paragraphs 7.1.4. and 7.2.1.8.1. must be fulfilled. If all tests during one year show satisfactory results, the manufacturer may, after agreement with the competent authority, reduce the frequencies as follows:

Child restraints, except booster cushions: Once every 16 weeks
Booster cushions: Once every 24 weeks

However, a minimum frequency of one test per year shall be permitted where annual production is 1,000 child restraint systems or less.

- 2.3.1. For vehicle-specific devices according to paragraph 2.1.2.4.1., the child restraint manufacturer may choose Conformity of Production procedures according to either paragraph 2.2., on a test seat, or paragraph 2.3., in a vehicle body shell.

- 2.4. Where a test sample fails a particular test to which it has been subjected, a further test to the same requirement shall be carried out on at least three other samples. In the case of dynamic tests if one of the latter fails the test, the holder of the approval or his duly accredited representative shall:

- 2.4.1. Notify the competent authority which has granted type approval indicating what steps have been taken to re-establish the conformity of production.

- 2.4.2. Raise the frequency to the higher one if the lower one was used according to paragraph 2.3.

- 2.5. The manufacturer must advise the competent authority on a quarterly basis, the volume of products produced against each

E/ECE/324
E/ECE/TRANS/505^a Rev.1/Add.43/Rev.1
Regulation No. 44
page 142
Annex 16

approval number, providing a means of identifying which products correspond to that approval number.

Annex 17

TEST OF ENERGY ABSORBING MATERIAL

1. Headform

- 1.1. The headform shall consist of a solid wooden hemisphere with an added smaller spherical segment as shown in Figure A below. It shall be constructed so that it can be dropped freely along the axis marked and it shall have provision for mounting an accelerometer in order to measure the acceleration along the direction of fall.
- 1.2. The headform shall have a total mass, including the accelerometer of 2.75 ± 0.05 kg.

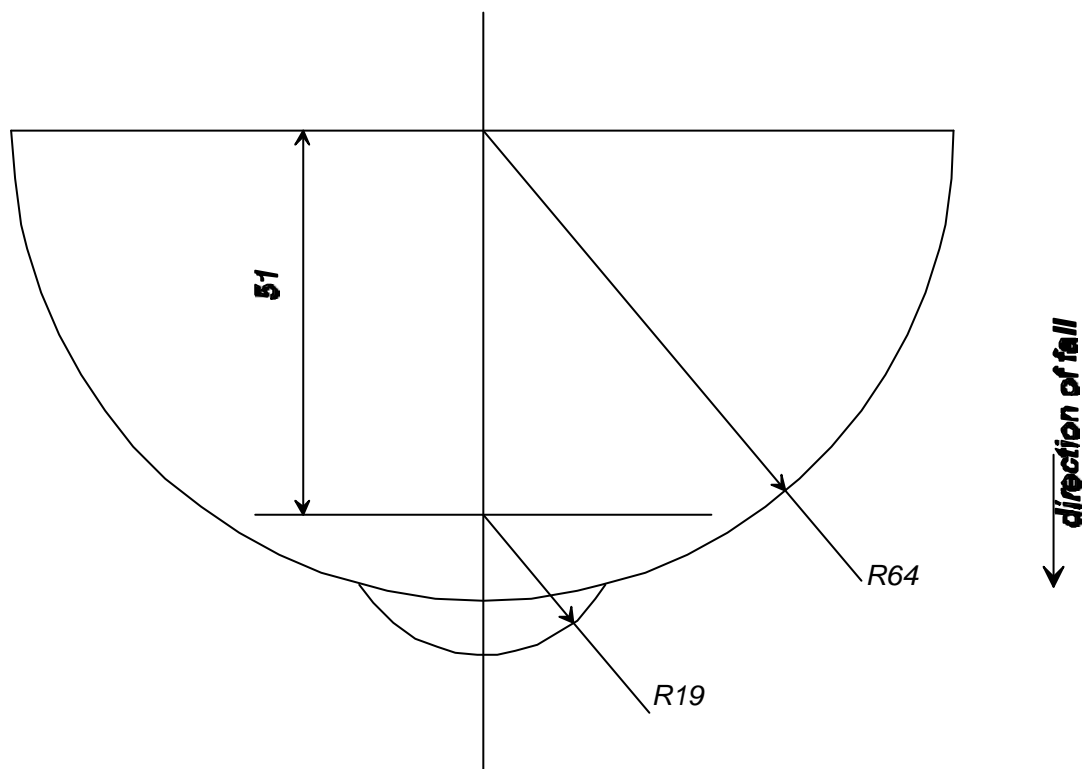

Dimensions in mm

Figure A: Headform

2. Instrumentation

The acceleration shall be recorded during the test, using equipment in accordance with channel frequency class 1000 as specified in the latest version of ISO 6487.

3. Procedure

3.1. Take three samples of each material from one or more child restraints.

3.2. The sample shall be fully restrained on its outer surfaces in the region of impact and be supported directly beneath the point of impact on a smooth rigid base, for example a solid concrete plinth, such that only the energy absorbing characteristics of the material construction are measured.

3.3. Raise the headform to a height of 100 -0/+5 mm from the upper surface of the sample to the lowest point on the headform, and allow it to fall. Record the acceleration experienced by the headform during impact. Repeat this procedure with the remaining samples.

Annex 18

METHOD OF DEFINING HEAD IMPACT AREA OF DEVICES
WITH BACKRESTS AND FOR REARWARD-FACING DEVICES DEFINING
THE MINIMUM SIZE OF SIDE WINGS

1. Place the device on the test seat described in annex 6. Reclinable devices shall be set in the most upright position. Place the smallest manikin in the device in accordance with the manufacturer's instructions. Mark a point 'A' on the backrest on the same horizontal level as the shoulder of the smallest manikin at a point 2 cm inside the outer edge of the arm. All internal surfaces above the horizontal plane passing through point A shall comprise special energy-absorbing material tested in accordance with annex 17. This material shall cover the internal surfaces of the backrest and side wings, including the inner edges (zone of radius) of the side wings. The energy absorbing material may be an integral part of the child seat.
 2. For rearward-facing devices there shall be side wings with a depth of minimum 90 mm measured from the median of the surface of the backrest. These side wings shall start at the horizontal plane passing through point "A" and continue to the top of the seat back. Starting from a point 90 mm below the top of the seat back, the depth of the side wing may be gradually reduced.
 3. The requirement in paragraph 2 above for a minimum size of side wings does not apply to child restraints of mass groups II and III in the specific vehicle category to be used in the luggage area according to paragraph 6.1.2. of this Regulation.
-

Annex 19

DESCRIPTION OF CONDITIONING OF ADJUSTERS
MOUNTED DIRECTLY ON CHILD RESTRAINTS

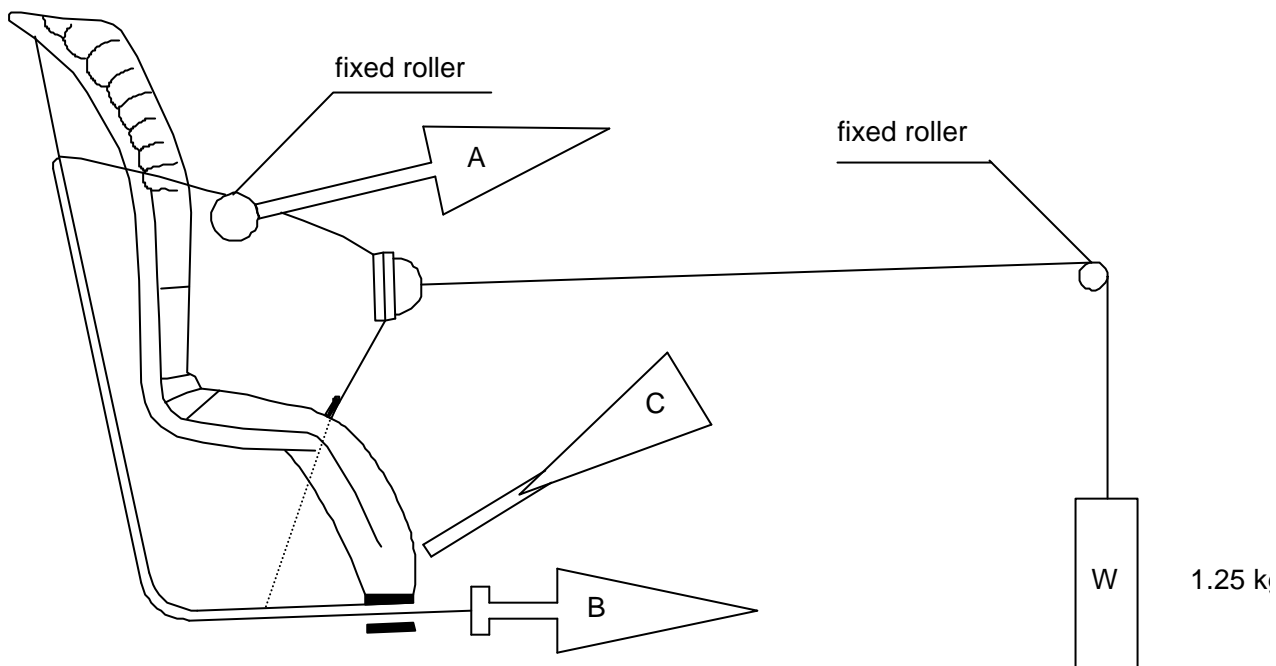

Figure 1

1. Method

- 1.1. With the webbing set at the reference position described in paragraph 8.2.7., withdraw at least 50 mm of webbing from the integral harness by pulling on the free end of the webbing.
- 1.2. Attach the adjusted part of the integral harness to the pulling device A.
- 1.3. Activate the adjuster and pull at least 150 mm of webbing into the integral harness. This represents half of one cycle and puts pulling device A to the maximum webbing extraction position.
- 1.4. Connect free end of webbing to pulling device B.

2. The cycle is:

- 2.1. Pull B at least 150 mm whilst A exerts no tension on the integral harness.
 - 2.2. Activate the adjusters and pull A whilst B exerts no tension on the free end of the webbing.
 - 2.3. At the end of stroke, de-activate the adjuster.
 - 2.4. Repeat cycle as specified in paragraph 7.2.2.7.
-

Annex 20

TYPICAL BUCKLE STRENGTH TEST DEVICE

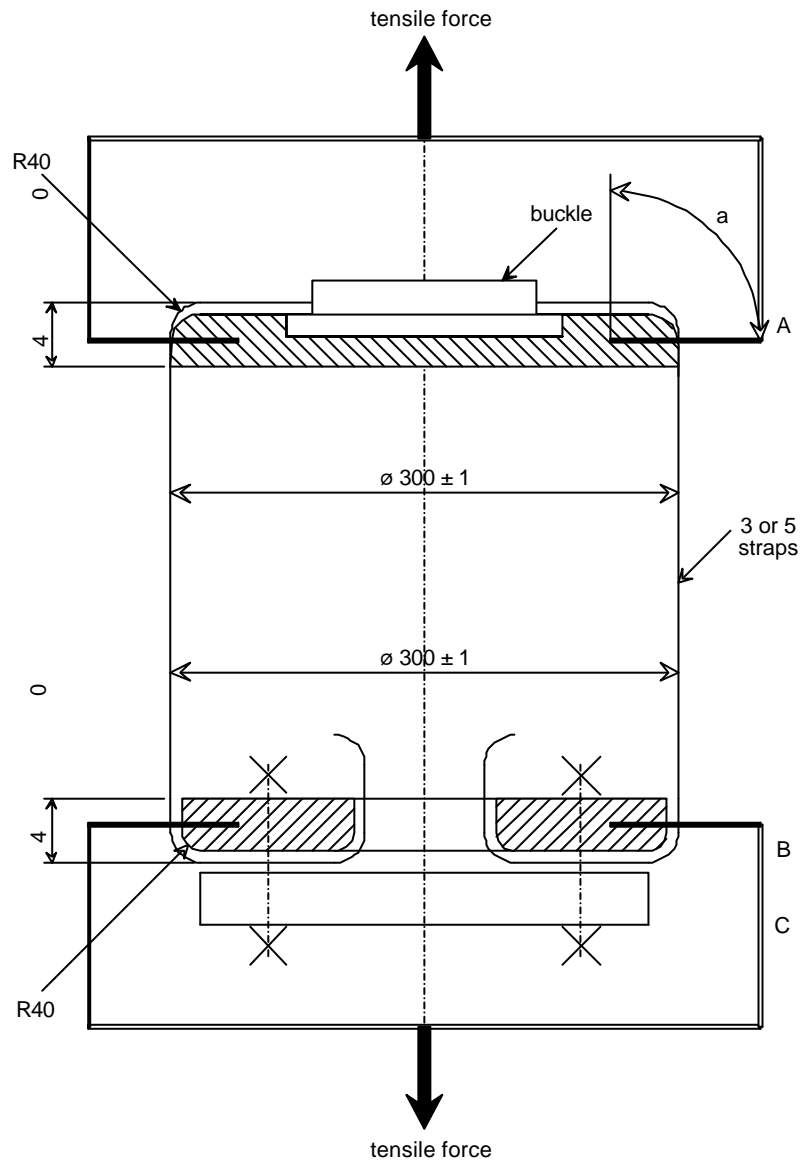

dimensions in mm
a = surface at A:



Annex 21
DYNAMIC CRASH TEST INSTALLATION

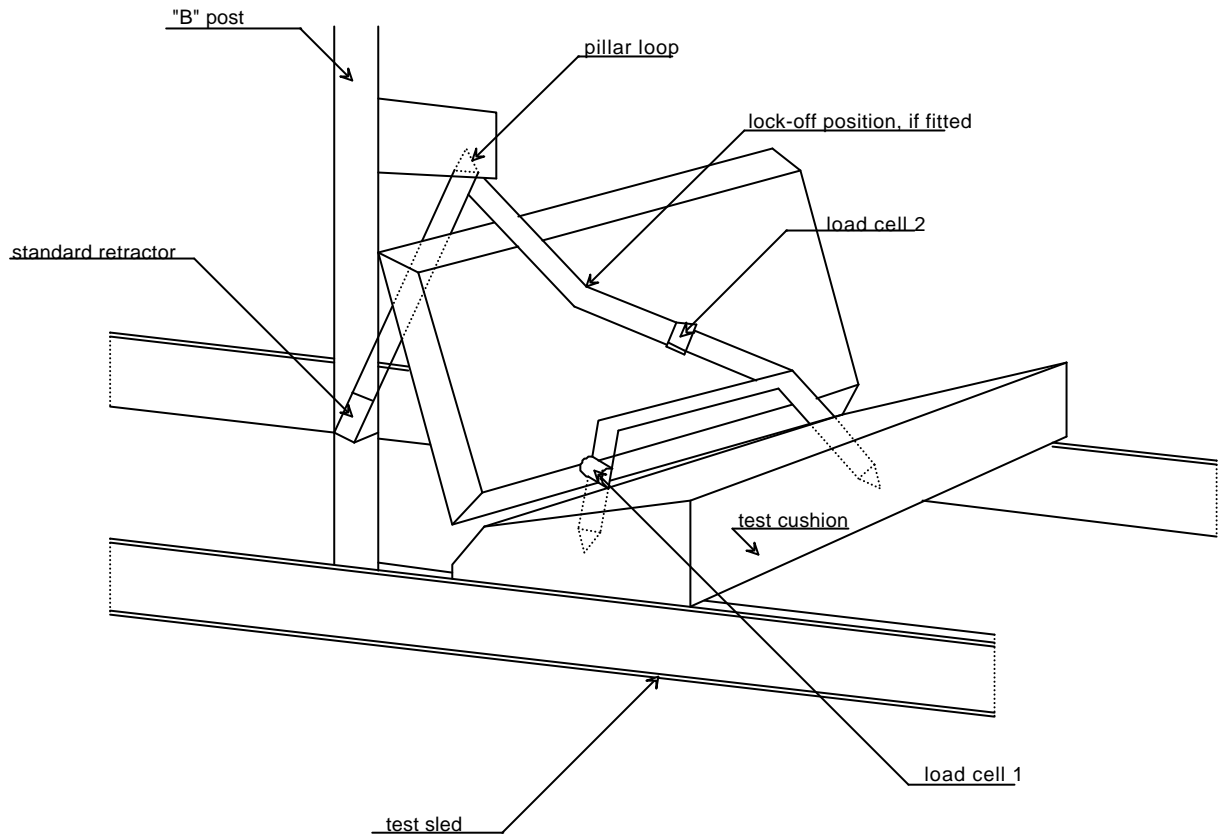

1. Method

1.1. Lap Belt Only

Fit load cell 1 to the outboard position as shown above. Install the child restraint and tension the reference belt at the outboard position to achieve a load of $75\text{N} \pm 5\text{N}$ at the outboard position.

1.2. Lap and Diagonal Belt

- 1.2.1. Fit load cell 1 to the outboard position as shown above. Install the child restraint into the correct position. If a lock-off device is fitted to the child restraint and acts upon the diagonal belt, place load cell 2 at a convenient position behind the child restraint between the lock-off device and the buckle as shown above. If no lock-off device is fitted or if the lock-off device is fitted at the buckle, position load cell at a convenient position between the pillar loop and the child restraint.

- 1.2.2. Adjust the lap portion of the reference belt to achieve a tension load of $50\text{N} \pm 5\text{N}$ at load cell 1. Make a chalk mark on the webbing where it passes through the simulated buckle. Whilst maintaining the belt at this position adjust the diagonal to achieve a tension of $50\text{N} \pm 5\text{N}$ at load cell 2 by either locking the webbing at the child restraint webbing locker or by pulling the belt close to the standard retractor.
- 1.2.3. Extract all webbing from the retractor spool and allow the tension in the belt between the retractor and pillar loop to drop to the retractor tension. The spool shall be locked before the dynamic test. Conduct the dynamic crash test.

NOTE

1. Installation is conducted after fitting the manikin into the restraint.
 2. Because the foam test cushion will compress after installation of the child restraint, the dynamic test must be conducted no more than 10 minutes after installation as possible. To allow the cushion to recover, the minimum period between two tests using the same cushion shall be 20 minutes.
 3. Load cells fitted directly onto the belt webbing may be disconnected electrically, but must be left in place during the dynamic test. The mass of each cell is not to exceed 250 grams. Alternatively the lap belt webbing load cell may be replaced by a load cell fixed at the anchorage point.
-

25 February 2000

AGREEMENT

**CONCERNING THE ADOPTION OF UNIFORM TECHNICAL PRESCRIPTIONS
FOR WHEELED VEHICLES, EQUIPMENT AND PARTS WHICH CAN BE FITTED
AND/OR
BE USED ON WHEELED VEHICLES AND THE CONDITIONS FOR RECIPROCAL
RECOGNITION
OF APPROVALS GRANTED ON THE BASIS OF THESE PRESCRIPTIONS */**

(Revision 2, including the amendments entered into force on 16 October 1995)

Addendum 43: Regulation No. 44

Revision 1 - Amendment 1

Supplement 2 to the 03 series of amendments: Date of entry into force: 18 November 1999

**~~UNIFORM PROVISIONS CONCERNING THE APPROVAL OF RESTRAINING DEVICES FOR CHILD OCCUPANTS OF POWER-DRIVEN
VEHICLES ("CHILD RESTRAINT SYSTEM")~~**



UNITED NATIONS

*/ Former title of the Agreement:

Agreement Concerning the Adoption of Uniform Conditions of Approval and Reciprocal Recognition of Parts, done at Geneva on 20 March 1958.

GE.00-

Insert a new paragraph 4.5., to read:

"4.5. In addition, in the immediate area where the child's head rests within the child restraint and on the visible surface of the child restraint system, rearward-facing restraints shall have the following label permanently attached (the text information shown is a minimum).

This label shall be provided in the language(s) of the country where the device is sold.

Label minimum size: 60 x 120 mm

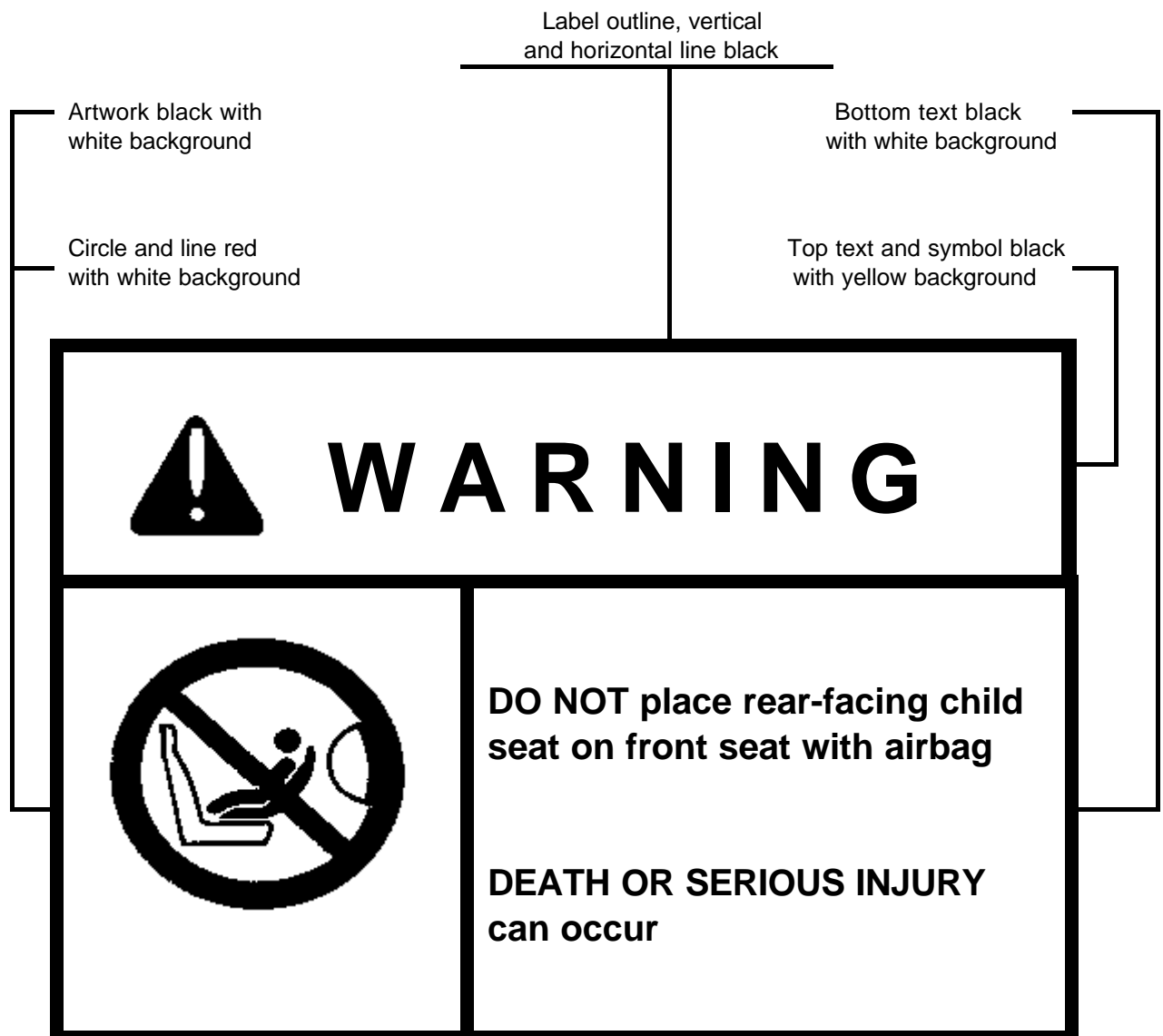

Paragraph 4.5. (former), renumber as paragraph 4.6.

Paragraph 5.4.1.1., footnote 1/, amend to read:

"1/ ..., 24 for Ireland, ..., 32 for Latvia, 33 (vacant), 34 for Bulgaria, 35-36 (vacant), 37 for Turkey, 38-39 (vacant), 40 for The former Yugoslav Republic of Macedonia, 41 (vacant), 42 for the European Community (Approvals are granted by its Member States using their respective ECE symbol) and 43 for Japan. Subsequent numbers shall be assigned to other countries in the chronological order in which they ratify or accede to the Agreement Concerning the Adoption of Uniform Technical Prescriptions for Wheeled Vehicles, Equipment and Parts which can be Fitted and/or be Used on Wheeled Vehicles and the Conditions for Reciprocal Recognition of Approvals Granted on the Basis of these Prescriptions, and the numbers thus assigned shall be communicated by the Secretary-General of the United Nations to the Contracting Parties to the Agreement."

Insert a new paragraph 16.8., to read:

"16.8. As from the date of entry into force of Supplement 2 to the 03 series of amendments, the label required by paragraph 4.5. of this Regulation shall be affixed to all new child restraints manufactured in conformity with this Regulation."

13 July 2001

AGREEMENT

CONCERNING THE ADOPTION OF UNIFORM TECHNICAL PRESCRIPTIONS
FOR WHEELED VEHICLES, EQUIPMENT AND PARTS WHICH CAN BE FITTED AND/OR
BE USED ON WHEELED VEHICLES AND THE CONDITIONS FOR RECIPROCAL RECOGNITION
OF APPROVALS GRANTED ON THE BASIS OF THESE PRESCRIPTIONS */

(Revision 2, including the amendments entered into force on 16 October 1995)

Addendum 43: Regulation No. 44

Revision 1 - Amendment 2

Incorporating:

Supplement 3 to the 03 series of amendments - Date of entry into force: 29 December 2000

Corrigendum 4 to the 03 series of amendments subject of Depository Notification C.N.134.2001.TREATIES-1 dated 13 March 2001

UNIFORM PROVISIONS CONCERNING THE APPROVAL OF RESTRAINING DEVICES
FOR CHILD OCCUPANTS OF POWER-DRIVEN VEHICLES ("CHILD RESTRAINT SYSTEM")



UNITED NATIONS

*/ Former title of the Agreement:

Agreement Concerning the Adoption of Uniform Conditions of Approval and Reciprocal Recognition of Approval for Motor Vehicle Equipment and Parts, done at Geneva on 20 March 1958.

GE.01-

Insert new paragraphs 4.7. and 4.8., to read:

- "4.7. In the case of child restraints with alternative belt routes, the alternative load bearing contact points between the child restraint and the adult safety-belt must be permanently marked. This marking shall indicate that it is the alternative belt route, and shall conform with the above coding requirements for forward and rearward facing seats.
- 4.8. If the child restraint offers alternative load bearing contact points, the marking required in paragraph 4.3. shall include an indication that the alternative belt route is described in the instructions."

Paragraph 5.4.1.1., footnote 1/, amend to read:

"... using their respective ECE symbol), 43 for Japan, 44 (vacant), 45 for Australia, 46 for Ukraine and 47 for South Africa. Subsequent numbers ..."

Paragraph 5.4.2.2.; amend to read:

- "5.4.2.2. the mass range for which the child restraint has been designed, namely, 0-10 kg; 0-13 kg; 9-18 kg; 15-25 kg; 22-36 kg; 0-18 kg; 9-25 kg; 15-36 kg; 0-25 kg; 9-36 kg; 0-36 kg."

Paragraph 6.1.2., amend to read:

".....whenever the restraint is ready to use. This is to be determined as a line perpendicular to the seat back through the eye line, the point of intersection shall be at least 40 mm below the start of radius of such a head support."

Paragraph 6.1.4., amend to read:

".....by either an adult belt, using the test as specified in paragraph 8.1.4., or by separate means."

Paragraph 6.1.8., amend to read:

"..... This shall apply to all adjustment configurations. Additional alternative belt routes are allowed. Where an alternative belt route exists, the manufacturer must make specific reference to the alternative route in the user instructions, as required in paragraph 14. When tested, using such alternative belt route(s), the restraint shall comply with all the requirements of the Regulation with the exception of this paragraph."

Paragraph 6.2.1.3., amend to read:

- "6.2.1.3. If it is possible to change the inclination of the restraint, this change in inclination shall not require manual readjustment of the straps. A deliberate hand-action is required in order to change the inclination of the restraint."

Insert new paragraphs 7.1.5. to 7.1.5.2., to read:

"7.1.5. Resistance to temperature

7.1.5.1. Buckle assemblies, retractors, adjusters and lock-off devices that are liable to be affected by temperature, shall be subject to the temperature test specified in paragraph 8.2.8. below.

7.1.5.2. After the temperature test as prescribed in paragraph 8.2.8.1., no signs of deterioration likely to impair the proper functioning of the child restraint, shall be visible to the unaided eye of a qualified observer."

Paragraph 7.2.1.2., amend to read:

"... and a width of not less than 10 mm. The width shall be the smaller of the two dimensions forming the prescribed area and shall be measured rectangular to the direction of movement of the release button."

Paragraph 7.2.1.7., amend to read:

"7.2.1.7. The buckle shall be capable of withstanding the temperature test operation requirements given in paragraph 8.2.8.1. and repeated operation, and shall, before the dynamic test prescribed in paragraph 8.1.3. undergo"

Paragraph 7.2.2.5., amend to read:

"..... adjusting devices shall be tested as prescribed by the temperature test operation requirements given in paragraph 8.2.8.1. and in paragraph 8.2.3. below."

Paragraph 7.2.3.1.3., amend to read:

"..... The retractor shall then be subjected to the temperature test operation requirements given in paragraph 8.2.8.1. and corrosion test described in paragraph 8.1.1"

Paragraph 7.2.3.2.6., amend to read:

"..... The retractor shall then be subjected to the temperature test operation requirements given in paragraph 8.2.8.1. and corrosion test described in paragraph 8.1.1"

Paragraph 7.2.5.2., amend to read:

"..... the durability of the adult belt and undergo temperature test operation requirements given in paragraph 8.2.8.1."

Paragraph 8.1.3.6.3.1., amend to read:

"8.1.3.6.3.1. The manikin shall be placed so that the gap is between the rear of the manikin and the restraint. In the case of carry-cots"

Paragraph 8.1.3.6.3.2., amend to read:

"8.1.3.6.3.2. Place the child chair on the test seat.
Place the manikin in the child chair.
Place a hinged board or a similar flexible device 2.5 cm thick and 6 cm wide and of length equal to the shoulder height (sitting, annex 8) less the hip centre height (sitting, in annex 8 popliteus height plus half of thigh height, sitting) relevant to the manikin size being tested between the manikin and the seat backof the manikin's hip joint.
Adjust the belt by the manufacturer.
Complete the installation annex 21 to this Regulation.
Remove the flexible device.
This only applies to harness restraints and to restraints where the child is restrained by the adult three-point belt and where a lock-off device is used and does not apply to child restraining straps connected directly to a retractor."

Paragraph 8.1.3.6.3.4., amend to read:

"..... masking tape of sufficient length and width. In the case of rear-facing restraints, it is permitted to use a light-weight masking tape to connect the dummy's head to the 100 mm bar or the back of the restraint during the sled acceleration."

Paragraph 8.1.3.7.7., amend to read:

"..... and the heaviest manikins specified above shall be carried out. The tests shall be conducted using the test seat as shown in annex 6, appendix 3, figure 3. The laboratory conducting the tests may, if it deems"

Insert a new paragraph 8.1.4., to read:

"8.1.4.

Restraint of booster cushions

Place a cotton cloth on the seating surface of the test bench. Position the booster cushion on the test bench, position the lower torso body block as described in annex 22, figure 1, on the seating surface, fit and apply the 3-point adult safety-belt and tension as prescribed in annex 21. With a piece of 25 mm width webbing or similar tied round the booster, apply a load of 250 ± 5 N in the direction of arrow A, see annex 22, figure 2, in line with the seating surface of the test bench."

Paragraph 8.2.1.1.2., amend to read.

"..... or the vehicle without opening the buckle. A load shall be applied to the buckle by direct traction via the strap tied to it so that all the straps are subjected to the force of $80/n$ daN; in this ratio "n" is the number of straps linked to the buckle when it is in a locked position, its minimum is deemed to be 2, if the buckle is connected to a rigid part. Account must be taken, when the force is applied, of the angle formed by the buckle and the rigid part during the dynamic test."

Insert new paragraphs 8.2.8. and 8.2.8.1., to read:

"8.2.8. Temperature test

8.2.8.1. The components specified in paragraph 7.1.5.1. shall be exposed to an environment over a water surface within a closed space, the environment having a temperature of not less than 80°C, for a continuous period of not less than 24 hours and then cooled in an environment having a temperature not exceeding 23°C. The cooling period shall immediately be followed by three consecutive 24 hour cycles with each cycle comprising the following consecutive sequences:

- (i) an environment having a temperature of not less than 100°C shall be maintained for a continuous period of 6 hours and this environment shall be attained within 80 minutes of commencement of the cycle; then
- (ii) an environment having a temperature of not more than 0°C shall be maintained for a continuous period of 6 hours and this environment shall be attained within 90 minutes; then
- (iii) an environment having a temperature of not more than 23°C shall be maintained during the remainder of the 24 hour cycle."

Paragraph 11., correct to read (Corr.4 to the 03 series):

"11. CONFORMITY OF PRODUCTION

The conformity of production procedures shall comply with those set out in the Agreement, appendix 2 (E/ECE/324-E/ECE/TRANS/505/Rev.2), with the following requirements:

- 11.1. Any child restraint system approved to this Regulation shall be so manufactured as to conform to the type approved by meeting the requirements set forth in paragraphs 6 to 8 above.
- 11.2. The minimum requirements for conformity of production control procedures set forth in annex 16 to this Regulation shall be complied with.
- 11.3. The authority which has granted type approval may at any time verify the conformity control methods applied in each production facility. The normal frequency of these verifications shall be twice a year."

Insert new paragraphs 14.3.14. to 14.3.17., to read:

- "14.3.14. There shall be a text or a diagram indicating how a user can identify an unsatisfactory position of the adult safety-belt buckle relative to the main load bearing contact points on the restraint. The user shall be advised to contact the child restraint manufacturer if in doubt about this point.
- 14.3.15. If the child restraint offers an alternative load bearing contact point, its use shall be described clearly. The user shall be informed about how to judge if use of this alternative route is satisfactory. The user shall be advised to contact the child

restraint manufacturer if in doubt about this point. The user shall be clearly advised to begin the child restraint installation, in vehicle seating positions categorized as "Universal" in the vehicle owner's manual, by using the primary belt route.

- 14.3.16. There shall be provisions made so that the instructions can be retained on the child restraint for its life period or in the vehicle handbook in the case of built-in restraints.
- 14.3.17. There shall be explicit warning not to use any load bearing contact points other than those described in the instructions and marked in the child restraint."

Annex 13,

Paragraph 3., amend to read:

"....
the value of X in Figure 1 below is 200 ± 5 mm. the value of P-A1 for "universal" and "semi-universal" restraints is 2220 ± 5 mm
..... The value of P-A1 for "restricted" child restraints is at least 2220 ± 5 mm, measured parallel to the centreline"

Annex 15,

Insert a new note to paragraph 6.1.8., to read:

"Paragraph 6.1.8.

The 150 mm requirement also applies to carry cots, except if a special device is used to link the carry cot and the safety-belt."

Note to paragraph 6.2.4., amend to read:

"Paragraph 6.2.4.

The limit of acceptable movement of the shoulder belt is that the lower edge of the shoulder portion of the standard safety-belt shall not be lower than the dummy's elbow at the point of maximum excursion of the dummy."

Insert a new note to paragraph 6.2.9., to read:

"Paragraph 6.2.9.

Common understanding is that it applies also to devices that have such a lock-off even if they are not required for that group. Thus the test would be applied to a group 2 only device, but at the prescribed force, i.e. twice the mass of group 1 dummy."

Annex 16,

Insert a new paragraph 1.7., to read:

"1.7. Temperature test

According to the provisions of paragraph 7.1.5. of this Regulation."

Annex 18,

Paragraph 1., amend to read:

"..... of the child seat. In the case of carry cot devices the lower limit of area at which material complying with annex 17 shall be used shall be all areas forward of the smaller dummy's rearward shoulder when measured with this dummy in the carry cot and the carry cot positioned on the test bench."

Annex 21,

Insert a new paragraph 1.2.4., to read:

"1.2.4. Before commencing the set-up, check the child restraint to determine compliance with paragraph 6.2.1.3. If there is a change in installation tension due to the change of angle function, then test for the condition which creates the slackest installation, conduct the set-up and tension in the tightest position and then reposition the child restraint to the worst case without re-tensioning the adult belt. Conduct the dynamic test."

Insert a new note 4., to read:

"4. In the case of restraints fitted with devices intended to increase the adult safety-belt tension, the test method shall be: Install the child restraint system as required in this annex and then apply the tensioner device as stated in the manufacturers instructions. If the device cannot be applied due to excess tension then it is deemed to be an unacceptable device."

Insert a new annex 22, to read:

"Annex 22

LOWER TORSO BODY BLOCK TEST

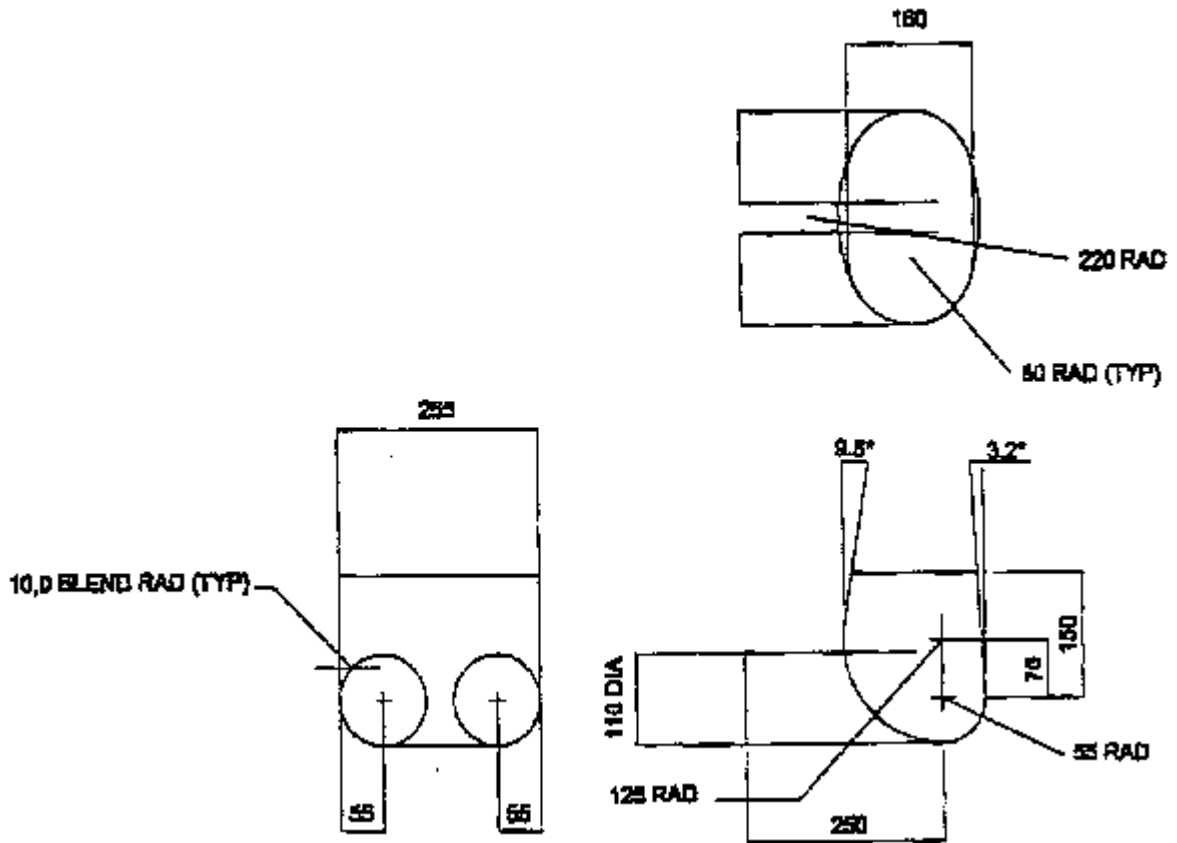

Figure 1: Truncated P10 manikin block
Material: EPS (40 to 45 g/l)

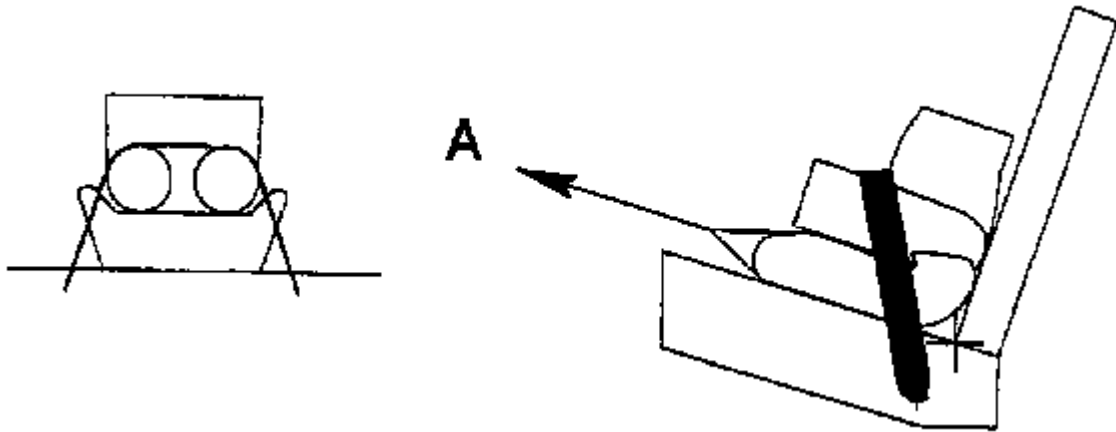

Figure 2 : Booster pull test using manikin block

_____”